

SHURE®

LEGENDARY
PERFORMANCE™

WIRED MICROPHONE

PGA 98H USER GUIDE



© 2015 Shure Incorporated
27A27348 (Rev. 2)
Printed in China



Clip-on Instrument Microphone

PG Alta Microphones

Congratulations on the purchase of a new Shure PG Alta series microphone. The PG Alta series delivers professional quality audio at an affordable price, with solutions for capturing nearly any source, including voice, acoustic instruments, drums, and amplified electric instruments. Suitable for live and studio applications, PG Alta microphones are built to last, and meet the same rigorous quality testing standards that make all Shure products trustworthy and reliable.

General Rules for Use

- Do not cover any part of the microphone grille with your hand, as this will adversely affect microphone performance.
- Aim the microphone toward the desired sound source (such as the talker, singer, or instrument) and away from unwanted sources.
- Place the microphone as close as practical to the desired sound source.
- Work close to the microphone for extra bass response.
- Use only one microphone to pick up a single sound source.
- For better gain before feedback, use fewer microphones.
- Keep the distance between microphones at least three times the distance from each microphone to its source ("three to one rule").
- Place microphones as far as possible from reflective surfaces.
- Add a windscreen when using the microphone outdoors.
- Avoid excessive handling to minimize pickup of mechanical noise and vibration.

Model Variations

PGA98H-XLR: Standard 3-pin XLR output with integrated belt-clip preamplifier (requires phantom power)

PGA98H-TQG: 4-pin TQG output for use with wireless transmitters

Phantom Power

All condenser microphones require phantom power to operate. This microphone performs best with a 48 V DC supply (IEC-61938), but it can operate with lower voltages.

Phantom power is provided by the mixer or audio interface that the microphone is connected to, and requires the use of a balanced microphone cable: XLR-to-XLR or XLR-to-TRS. In most cases, there is a switch or button to activate the phantom power. See the user guide for the mixer or interface for additional information.

NOTE: This microphone is compatible with non-Shure bodypacks that have a TQG connector and supply 5V on pin 2.

Mounting the Microphone

Use the integrated clamp to quickly and securely attach the microphone to horns or other instruments.

1. Squeeze the clamp to open it, and attach to an instrument or other object.
2. Aim the microphone by rotating the swivel base and bending the gooseneck.

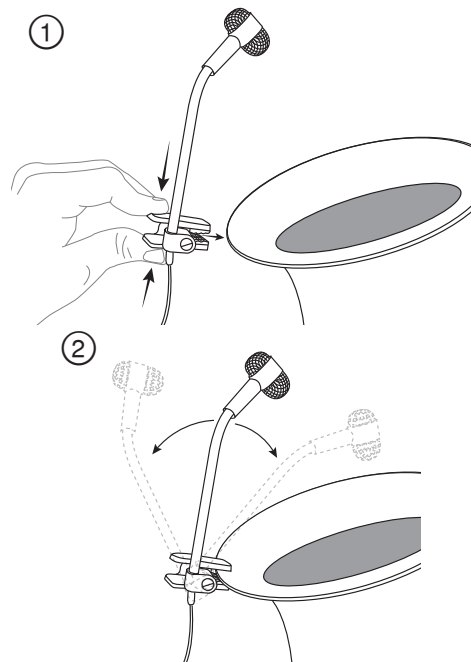

Aiming the Microphone

Position the microphone with the arrow pointed at the sound source.



Applications And Placement

The following table lists the most common applications and placement techniques. Keep in mind that microphone technique is largely a matter of personal taste; there is no one "correct" microphone position.

Application	Suggested Microphone Placement	Tone Quality
Reed Instruments	Place microphone a few inches from and aiming into bell.	Bright, minimizes feedback and leakage.
Brass & Woodwinds	Brass: 30 to 90 cm (1 to 3 ft.) away, on-axis with bell of instrument.	Bright, clear sound.
	Woodwinds: 2.5 to 15 cm (1 to 6 in.) away, on-axis with bell of instrument.	Bright, clear sound.
	Bell of instrument 90° off-axis from front of mic.	Softer, mellow sound.

Accessories

Foam windscreen for PGA98H and PGA98D microphones	AP98WS
---	--------

Specifications

Type

Electret Condenser

Polar Pattern

Cardioid

Frequency Response

60 to 20,000 Hz

Output Impedance

at 1 kHz

PGA98H-XLR	850 Ω
PGA98H-TQG	600 Ω

Sensitivity

at 1 kHz, open circuit voltage

-52 dBV/Pa[1] (2.51 mV)

Maximum SPL

1 kHz at 1% THD, 1 kΩ load, typical

130 dB SPL

Self Noise

A-weighted, typical

27 dB SPL-A

Polarity

PGA98H-XLR	Positive pressure on diaphragm produces positive voltage on pin 2 with respect to pin 3
PGA98H-TQG	Positive pressure on diaphragm produces positive voltage on pin 3 with respect to pin 1

Connector

PGA98H-XLR	Three-pin professional audio (XLR), male
PGA98H-TQG	TA4F

Weight

PGA98H-XLR	245 g (0.5 lbs)
PGA98H-TQG	75 g (0.2 lbs)

Housing

Cast Zinc

Power Requirements

11 to 52 V DC phantom power (2 mA)

[1] 1 Pa=94 dB SPL

Certifications

This product meets the Essential Requirements of all relevant European directives and is eligible for CE marking.

The CE Declaration of Conformity can be obtained from:
www.shure.com/europe/compliance

Authorized European representative:
 Shure Europe GmbH
 Headquarters Europe, Middle East & Africa
 Department: EMEA Approval
 Jakob-Dieffenbacher-Str. 12
 75031 Eppingen, Germany
 Phone: 49-7262-92 49 0
 Fax: 49-7262-92 49 11 4
 Email: info@shure.de

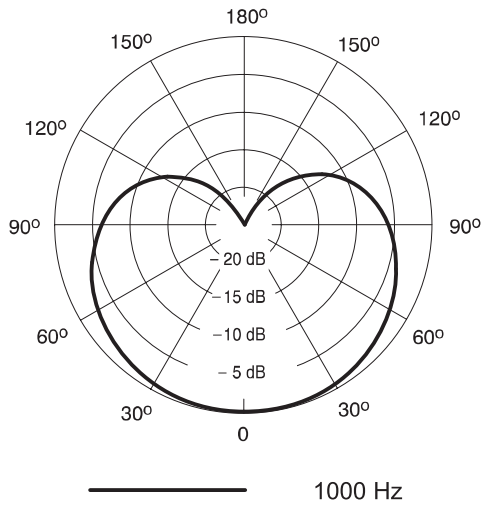
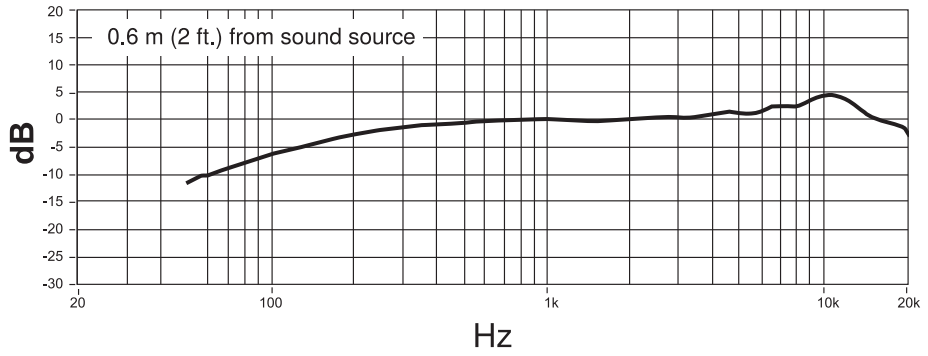

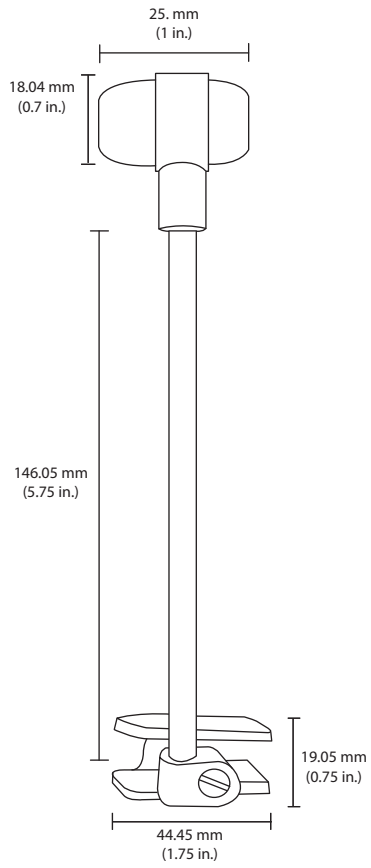

SHURE[®]
LEGENDARY
PERFORMANCE™

United States, Canada,
Latin America, Caribbean:
Shure Incorporated
5800 West Touhy Avenue
Niles, IL 60714-4608 USA

Phone: +1 847-600-2000
Fax: +1 847-600-1212 (USA)
Fax: +1 847-600-6446
Email: info@shure.com
www.shure.com

Europe, Middle East, Africa:
Shure Europe GmbH
Jakob-Dieffenbacher-Str. 12,
75031 Eppingen, Germany

Phone: +49-7262-92490
Fax: +49-7262-9249114
Email: info@shure.de
www.shure.eu

Asia, Pacific:
Shure Asia Limited
22/F, 625 King's Road
North Point, Island East
Hong Kong

Phone: +852-2893-4290
Fax: +852-2893-4055
Email: info@shure.com.hk
www.shureasia.com