



evolution wired e 602-II



The e 602-II is a cardioid instrument microphone especially suitable for use with bass drums, bass guitar cabs, tubas and other low frequency instruments.

SPECIFICATIONS

Transducer principle	dynamic
Frequency response	20 - 16,000 Hz
Pick-up pattern	cardioid
Sensitivity (free field)	0.9 mV/Pa (at 50 Hz) 0.25 mV/Pa (at 1 kHz)
Nominal impedance (at 1 kHz)	350 Ω
Min. terminating impedance	1 k Ω
Connector	XLR-3
Dimensions	\varnothing 60 x 153 mm
Weight	318 g

FEATURES

- Rugged, lightweight aluminium body for stable positioning on long microphone boom arms
- Lightweight high-performance voice coil construction
- Fast transient response
- Low frequency extension
- Ideal for direct use on the most problematic bass signal sources
- Frequency-independent directivity provides isolation from other on-stage signals
- Hum compensating coil
- Integral stand mount

DELIVERY INCLUDES

- e 602-II
- pouch
- quick guide
- safety guide

ARCHITECT'S SPECIFICATION

The microphone shall be a dynamic cardioid designed for use with low frequency instruments. It shall have a rugged aluminium body with an integral stand mount and shall be fitted with a hum compensating coil.

The frequency response shall be 20 Hz – 16,000 Hz and the sensitivity (free field, no load) shall be 0.25 mV/Pa at 1 kHz and 0.9 mV/Pa at 50 Hz. Nominal impedance shall be 350 Ω , with a min. terminating impedance of 1 k Ω .

The microphone shall provide a 3-pin XLR connector. Dimensions shall be 60 x 153 mm (2.36" x 6.02"). Weight shall be 318 grams (11.22 oz).

The microphone shall be the Sennheiser e 602-II.



evolution wired e 602-II

DIMENSIONS

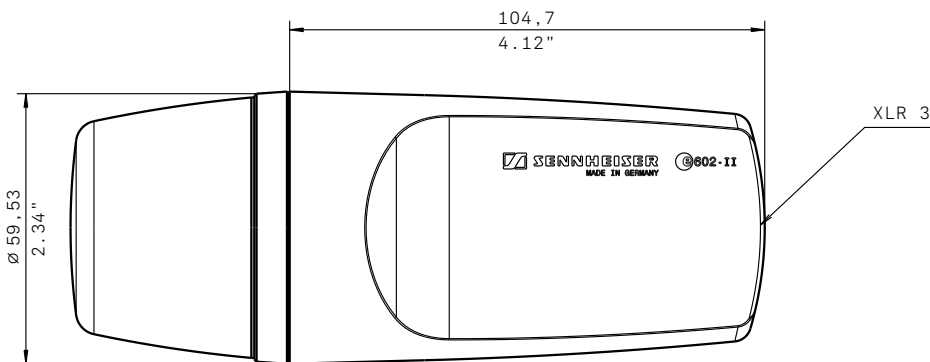
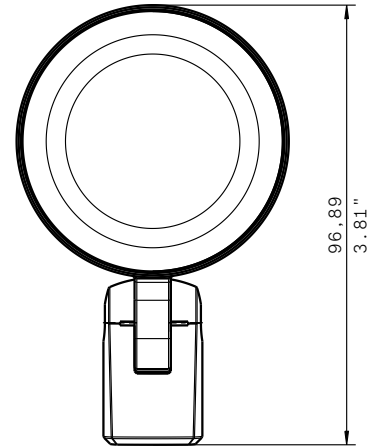
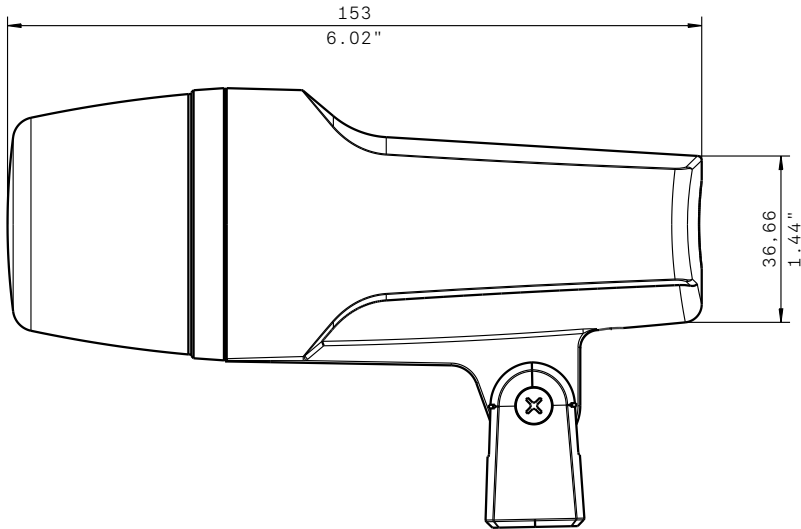

POLAR PATTERN

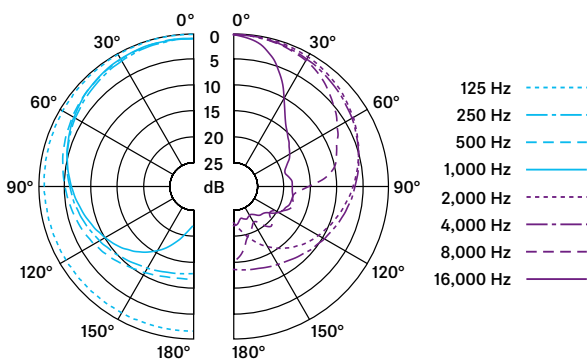

FREQUENCY RESPONSE

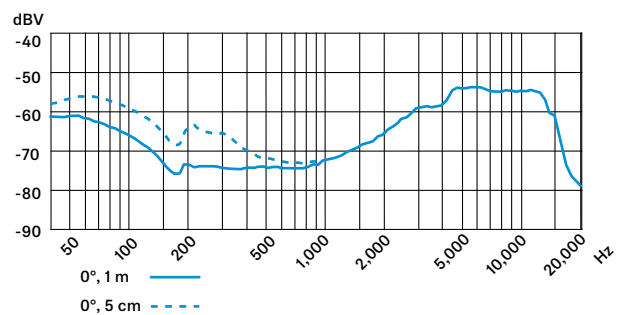



evolution wired e 604



The frequency response and cardioid pick-up pattern are optimized for drum sets and other percussion instrument miking, while also producing exceptional results on all forms of brass and woodwind.

An integral stand mount screws directly onto mic stands and included clip attaches mic to rims of drums. Very high sound pressure level handling, in excess of 160 dB, is combined with a balanced, clear, low distortion signal.

Lightweight voice coil provides extended high frequency and rapid transient response. A tough reinforced glass fiber body takes the knocks and shocks.

FEATURES

- Rugged reinforced glass fiber body
- Low sensitivity to impact and handling noise
- Very high sound pressure handling capability (in excess of 160 dB)
- Low distortion microphone
- Hum compensating coil
- Easy to position due to compact design
- Integral stand mount

DELIVERY INCLUDES

- e 604
- pouch
- MZH 604 drum clip
- quick guide
- safety guide

SPECIFICATIONS

Transducer principle	dynamic
Frequency response	40 - 18,000 Hz
Pick-up pattern	cardioid
Sensitivity (free field, at 1 kHz)	1.8 mV/Pa
Nominal impedance (at 1 kHz)	350 Ω
Min. terminating impedance	1 k Ω
Connector	XLR-3
Dimensions	\varnothing 33 x 59 mm
Weight	60 g

ARCHITECT'S SPECIFICATION

The instrument microphone shall be a dynamic cardioid designed for use with drums and percussion as well as brass and woodwind instruments.

It shall have a compact design and a rugged reinforced glass fiber body and shall feature an integral stand mount. The microphone shall be fitted with a hum compensating coil. The frequency response shall be 40 Hz – 18,000 Hz and the sensitivity (free field, no load) shall be 1.8 mV/Pa at 1 kHz. Nominal impedance shall be 350 Ω , with a min. terminating impedance of 1 k Ω . The microphone shall provide a 3-pin XLR connector. Dimensions shall be 33 x 59 mm (1.3" x 2.32"). Weight without cable shall be 60 grams (2.12 oz).

The microphone shall be the Sennheiser e 604.



evolution wired e 604

DIMENSIONS

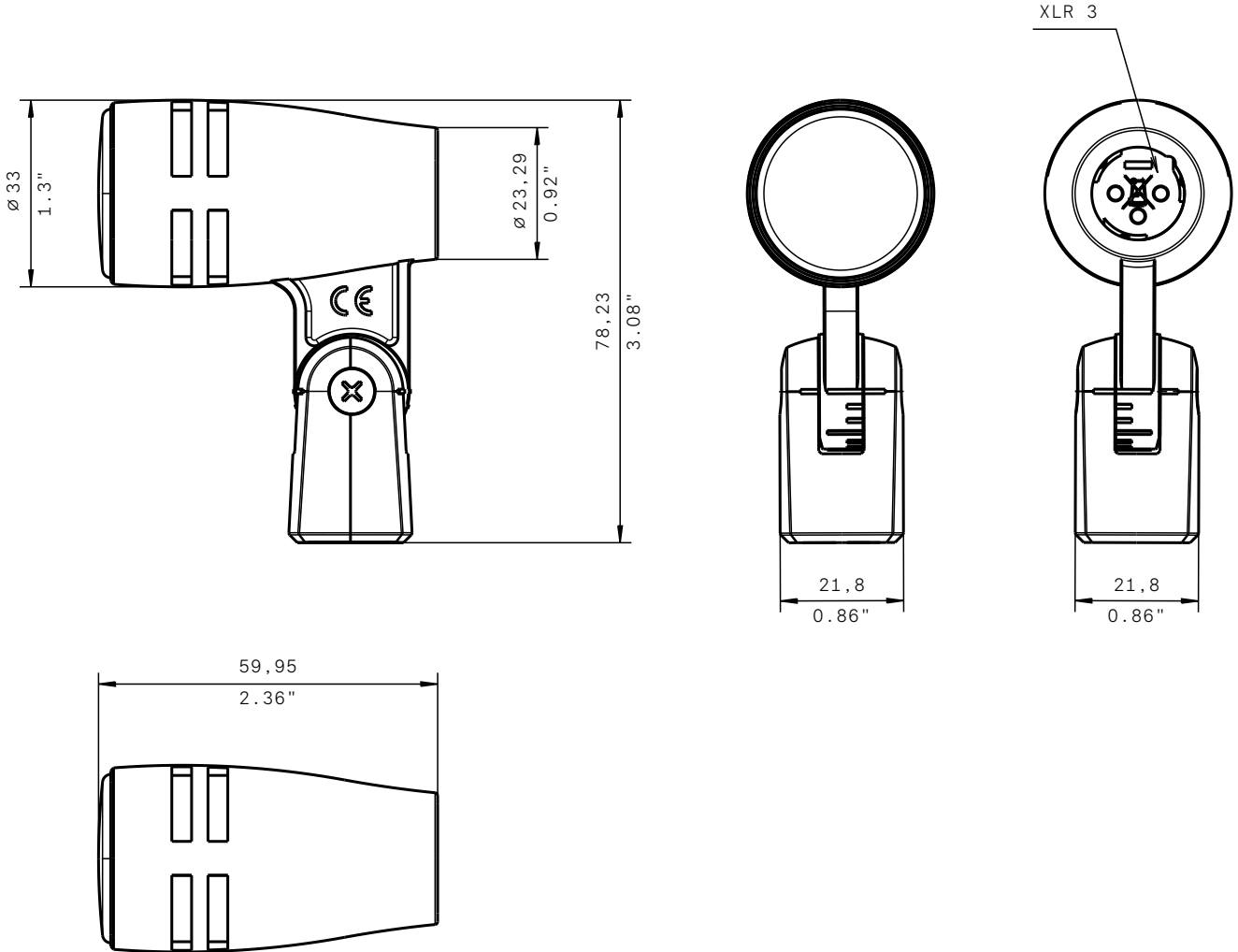

POLAR PATTERN

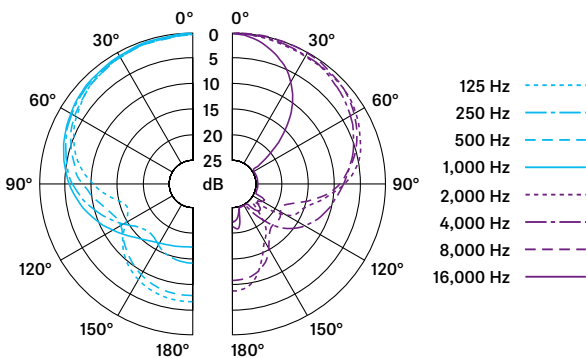

FREQUENCY RESPONSE

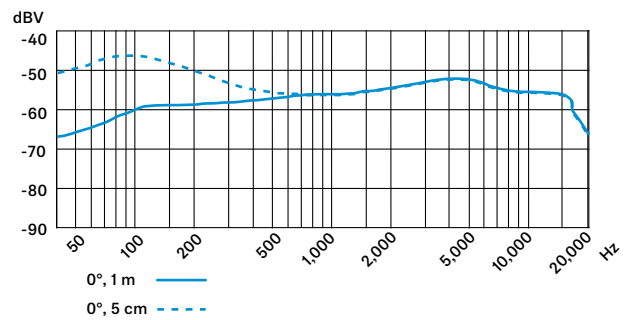



evolution wired e 614



The e 614 is a super-cardioid condenser microphone, designed for demanding instrument recordings and performances that require extended frequency response, high SPL handling, fast transient response and compact size.

While drumset overhead miking was the first design priority, the e 614 also works exceptionally well on percussion setups as well, fitting comfortably into tight setups. The e 614 can handle high SPLs and features medium sensitivity, which ensures reduced bleed from other instruments on stage. Because of its excellent acoustic properties, this mic is also ideal for home recording.

DELIVERY INCLUDES

- e 614
- pouch
- MZQ 100 microphone clamp
- quick guide
- safety guide

SPECIFICATIONS

Transducer principle	pre-polarised condenser microphone
Frequency response	40 - 20,000 Hz
Pick-up pattern	super-cardioid
Sensitivity (free field, at 1 kHz)	3 mV/Pa
Nominal impedance (at 1 kHz)	50 Ω
Min. terminating impedance	1 kΩ
Max. sound pressure level (at 1 kHz)	139 dB
Equivalent noise level	
A-weighted	24 dB(A)
CCIR-weighted	35 dB
Phantom powering	12 - 48 V
Connector	XLR-3
Dimensions	∅ 20 x 100 mm
Weight	93 g

FEATURES

- Rugged design
- Effective rejection of incidental rear noise
- Excellent directivity across the whole frequency range
- Full, natural sound
- High maximum sound pressure level
- Wide frequency response

ARCHITECT'S SPECIFICATION

The rugged microphone shall be a super-cardioid pre-polarized condenser designed for demanding instrument miking applications. The frequency response shall be 40 Hz – 20,000 Hz and the sensitivity (free field, no load) shall be 3 mV/P at 1 kHz. Maximum SPL shall be 139 dB at 1 kHz. Nominal impedance shall be 50 Ω, with a min. terminating impedance of 1 kΩ.

The microphone shall operate on 12 – 52 V phantom power and shall provide a 3-pin XLR connector. Dimensions shall be 20 x 100 mm (0.79" x 3.94"). Weight shall be 93 grams (3.28 oz).

The microphone shall be the Sennheiser e 614.



evolution wired e 614

DIMENSIONS

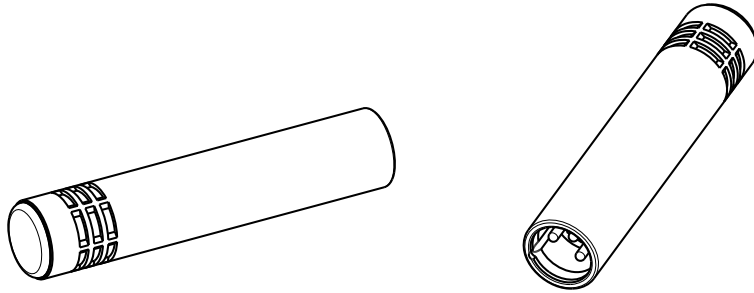
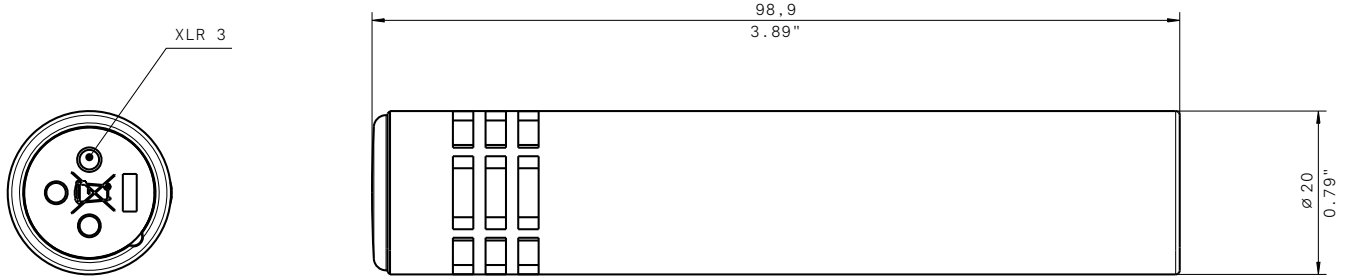

POLAR PATTERN

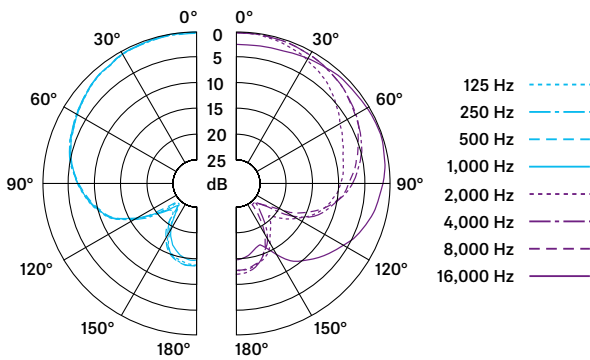

FREQUENCY RESPONSE

