

The Shure RK244G is a replacement screen and grille assembly for the Model SM57 microphone. The RK244G consists of the complete screen and grille assembly, an extra retainer ring, and nameplate.

REMOVAL

CAUTION: Use extreme care in removing the screen and grille assembly. Avoid damaging the clear plastic diaphragm! Bending or tearing the diaphragm will affect the microphone response, and may require complete cartridge replacement.

3. Wrap the new retainer ring around the cartridge groove just above the perforated collar.
4. Hold the two ends of the retainer ring closed around the cartridge and center them above a flat area on the side of the cartridge.
5. Hook the crimped tab at the back of the retainer ring into one of the two slots in the grille.
6. Lower the front edge of the grille assembly over the retainer ring until it contacts the tops of the two metal tabs and holds the retainer ring closed. **Be sure the collar is tucked underneath the grille.**
7. Use a small screwdriver to tuck the two metal tabs under the edge of the grille assembly. Continue lowering the grille assembly into place until the tabs lock into the slot on the retainer ring.
8. When properly assembled, the grille assembly can be rotated while the perforated collar is held in one position.
9. Remove the paper backing from the replacement nameplate. Locate the raised index mark along the lower edge of the grille assembly and affix the nameplate so that it covers the retainer ring holes, but not the index mark.

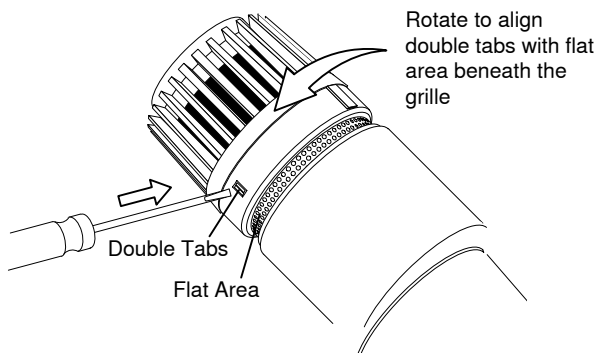

1. Peel the old nameplate off and discard it.
2. Rotate the grille assembly until the two metal tabs are centered above one of the recessed flat areas (visible through the perforated collar). Refer to the exploded diagram above.
3. Use a small (1/16 in. blade maximum) screwdriver to depress the two metal tabs while you lift the grille up and over the metal tabs.

INSTALLATION

CAUTION: As in the disassembly process above, take care not to damage the clear plastic diaphragm!

1. Remove the retainer ring from the new screen and grille assembly.
2. Insert pad into grille assembly and press resonator on top of pad. **Be sure the indented side of resonator is facing away from foam pad (see exploded diagram).**

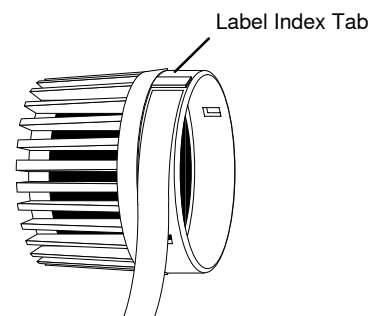

If you have a Shure microphone that requires a different nameplate (SM77, PE65, PE66, 545, etc.), please contact Shure's Service Department.

SHURE®

SHURE Incorporated <http://www.shure.com>
United States, Canada, Latin America, Caribbean:
5800 W. Touhy Avenue, Niles, IL 60714-4608, U.S.A.
Phone: 847-600-2000 U.S. Fax: 847-600-1212 Int'l Fax: 847-600-6446
Europe, Middle East, Africa:
Shure Europe GmbH, Phone: 49-7262-92490 Fax: 49-7262-9249114
Asia, Pacific:
Shure Asia Limited, Phone: 852-2893-4290 Fax: 852-2893-4055