

Power amplifier

V600:4

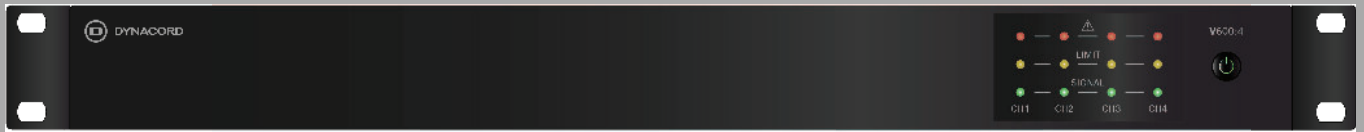

Table of contents

| | | |
|-----------|------------------------------------------------------|-----------|
| 1 | Important product information | 4 |
| 1.1 | Safety Information | 4 |
| 1.2 | Disposal instructions | 5 |
| 1.3 | Class B Notice for FCC and ICES 003 | 5 |
| 2 | About this manual | 6 |
| 2.1 | Digital document | 6 |
| 2.2 | Intended audience | 6 |
| 2.3 | Copyright notice | 6 |
| 2.4 | Trademarks | 6 |
| 2.5 | Notice of liability | 6 |
| 2.6 | Document history | 7 |
| 3 | Product introduction | 8 |
| 3.1 | Features and functions | 8 |
| 3.2 | Functional diagram | 10 |
| 4 | General installation procedures | 11 |
| 4.1 | Unpacking | 11 |
| 4.2 | Parts included | 11 |
| 4.3 | Dimensions | 12 |
| 4.4 | Mounting and ventilation | 12 |
| 4.5 | Fan cooling | 14 |
| 4.6 | Mains operation and resulting temperature | 15 |
| 5 | Installation | 16 |
| 5.1 | Indicators, controls and settings | 16 |
| 5.1.1 | Set the output mode (AMP MODE) | 17 |
| 5.1.2 | Set the input routing (DUAL / PARALLEL / IN1 to ALL) | 18 |
| 5.1.3 | Set the loudspeaker parameters (SPEAKER EQ) | 19 |
| 5.1.4 | Set the energy safe option (APD) | 20 |
| 5.1.5 | ecoRAIL | 20 |
| 5.2 | Connections | 21 |
| 5.2.1 | Audio inputs | 21 |
| 5.2.2 | AMP-LINK | 23 |
| 5.2.3 | Power outputs | 24 |
| 5.2.4 | Ready/Fault relay | 25 |
| 5.2.5 | Remote on | 26 |
| 5.2.6 | Mains power | 26 |
| 6 | Operation after installation | 27 |
| 6.1 | Power on | 27 |
| 6.2 | Input level control | 27 |
| 7 | Troubleshooting | 28 |
| 8 | Maintenance | 30 |
| 9 | Technical data | 31 |
| 10 | Approvals | 34 |
| 11 | Block diagram | 35 |
| 12 | Support and academy | 36 |

1 Important product information

1.1 Safety Information

1. Read and keep these safety instructions. Follow all instructions and heed all warnings.
2. Download the latest version of the applicable installation manual from www.dynacord.com for installation instructions.



Information

Refer to the Installation Manual for instructions.

3. Follow all installation instructions and observe the following alert signs:



Notice! Containing additional information. Usually, not observing a notice does not result in damage to the equipment or personal injuries.



Caution! The equipment or the property can be damaged, or persons can be injured if the alert is not observed.





Warning! Risk of electric shock.

4. System installation and servicing by qualified personnel only, in accordance with applicable local codes. No user-serviceable parts inside.
5. System installation for emergency sound (except for call stations and call station extensions) in a Restricted Access Area only. Children may not get access to the system.
6. For rack-mounting of system devices, make sure that the equipment rack is of suitable quality to support the weight of the devices. Use caution when moving a rack to avoid injury from tip over.
7. The apparatus shall not be exposed to dripping or splashing and no objects filled with liquids, such as vases, shall be placed on the apparatus.



Warning! To reduce the risk of fire and electric shock, do not expose this apparatus to rain or moisture.

8. Mains powered equipment shall be connected to a mains power outlet socket with a protective earthing connection. An external, readily operable, mains plug or all-pole mains switch shall be installed.
9. Only replace the mains fuse of an apparatus with a fuse of the same type.
10. The protective ground connection of an apparatus shall be connected to protective ground before the apparatus is connected to a power supply.
11. This unit has an autoranging input circuitry suitable for 100-240 Vac.
12. Amplifier outputs marked with  may carry audio output voltages up to $120 V_{\text{RMS}}$. Touching uninsulated terminals or wiring may result in an unpleasant sensation. Amplifier outputs marked with  or f may carry audio output voltages above $120 V_{\text{RMS}}$. It requires a skilled person to strip and connect the loudspeaker wires in such a way that the naked conductors are inaccessible.
13. To prevent hearing damage do not listen at high volume levels for long periods.

1.2 Disposal instructions



Old electrical and electronic appliances.

Electrical or electronic devices that are no longer serviceable must be collected separately and sent for environmentally compatible recycling (in accordance with the European Waste Electrical and Electronic Equipment Directive).

To dispose of old electrical or electronic devices, you should use the return and collection systems put in place in the country concerned.

1.3 Class B Notice for FCC and ICES 003

This equipment has been tested and found to comply with the limits for a Class B digital device, pursuant to part 15 of the FCC Rules and Canadian ICES-003 requirements. These limits are designed to provide reasonable protection against harmful interference in a residential installation. This equipment generates, uses and can radiate radio frequency energy and, if not installed and used in accordance with the instructions, may cause harmful interference to radio communications. However, there is no guarantee that interference will not occur in a particular installation. If this equipment does cause harmful interference to radio or television reception, which can be determined by turning the equipment off and on, the user is encouraged to try to correct the interference by one or more of the following measures:

- Reorient or relocate the receiving antenna.
- Increase the separation between the equipment and receiver.
- Connect the equipment into an outlet on a circuit different from that to which the receiver is connected.
- Consult the dealer or an experienced radio/TV technician for help.

2 About this manual

The purpose of this manual is to provide information required for installing, configuring, operating and maintaining this product.

Read through this manual to familiarize yourself with the safety information, features, and applications before you use it.

2.1 Digital document

This manual is available as a digital document in the Adobe Portable Document Format (PDF). You can find information about Dynacord products on the product related information at www.dynacord.com.

2.2 Intended audience

This manual is intended for everyone who is authorized to install and use this product.

2.3 Copyright notice

Unless otherwise indicated, this publication is the copyright of Dynacord. All rights are reserved.

2.4 Trademarks

Throughout this document trademark names may have been used. Rather than put a trademark symbol in every occurrence of a trademark name, Dynacord states that the names are used only in an editorial fashion and to the benefit of the trademark owner with no intention of infringement of the trademark.

2.5 Notice of liability

While every effort has been taken to ensure the accuracy of this document, neither Dynacord nor any of its official representatives shall have any liability to any person or entity with respect to any liability, loss or damage caused or alleged to be caused directly or indirectly by the information contained in this document.

Dynacord reserves the right to make changes to features and specifications at any time without prior notification in the interest of ongoing product development and improvement.

2.6

Document history

| Release date | Documentation version | Reason |
|--------------|-----------------------|---------|
| 2022.02.01 | V1 | Release |

| Release date | Documentation version | Reason |
|--------------|-----------------------|---------|
| 2022.02.01 | V1 | Release |

3 Product introduction



The V600:4 is a 600 W power amplifier with powerTANK technology that flexibly delivers the total power over its 4 channels.

The amplifier is ideally suited to background music and clear voice announcement applications such as:

- Supermarkets
- Bars and restaurants
- Retail outlets
- Education
- Houses of worship
- Museums and galleries
- Transport hubs
- Conference centers

3.1 Features and functions

- 4-channel amplifier, with a total powerTANK capacity of 600 W
powerTANK is a reservoir of available amplification power that is deployed flexibly across the 4 channels of the amplifier. There is no need to set up the powerTANK as it adapts to the requirements of each zone or output without extra manual configuration of each individual channel.
- dualCOOL convection cooling with additional intelligent fan in case of extreme thermal conditions
The dualCOOL thermal design means that the amplifier typically operates as a convection cooled amplifier, but in extreme thermal conditions the amplifier is also equipped with an intelligent multi-speed fan to ensure maximum performance and reliability in any application.
- ecoRAIL and APD deliver significant reduction in power consumption
ecoRAIL's power consumption is similar to a regular standby level, yet ecoRAIL still produces audio output suitable for background music levels, and the Auto Power Down (APD) mode can be engaged to further reduce power consumption to less than a watt when there is no signal present for extended periods.
- Variable Load Drive (VLD) providing the same power into 4 Ω , 8 Ω , 70 V or 100 V
Variable Load Drive (VLD) ensures that the powerTANK capacity is utilized efficiently, providing consistent power to any channel with any impedance.
- amp-LINK single cable solution for easy installation
The single cable installation feature of amp-LINK is compatible with AES72-1E (RJ45 connectors) wired devices. This solution provides easy installation for all four channels without needing to wire all the connections individually.
- Advanced Protection features and PFC to ensure reliability







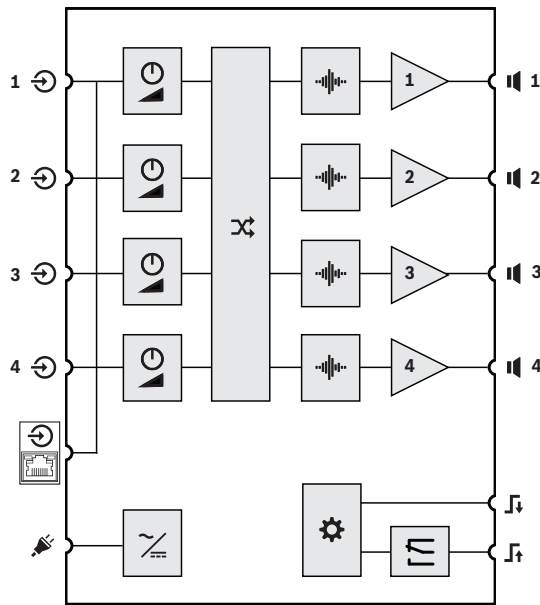





Equipped with a PFC power supply and protection features usually reserved for the professional power amplifiers, means that the amplifier resists complete shutdown situations and will always perform at its best under all conditions.

3.2 Functional diagram

Functional and connection diagram



Internal and external device functions

-  Signal input
-  AMP-LINK input
-  Mains input
-  Loudspeaker output
-  REMOTE ON Input
-  RDY/FLT Output
-  Level control
-  Input routing
-  Signal processing (filter, limiter)
-  Amplifier
-  Power supply
-  Controller
-  Failure relay

4 General installation procedures

Before starting installation, ensure the following:

- You make use of manufacturer specified installation materials.
- No liquids can spill into or on the products.
- Installation is in a clean environment free of dust.
- The ventilation airflow of the 19" units is not obstructed.
- There is a mains power outlet of sufficient rating close to the intended location of the products.
- Sufficient free space and access at the rear of the 19" units for connectors and wiring.

4.1 Unpacking

The products should be unpacked and handled with care. If an item appears to be damaged, notify the shipper immediately. If any items are missing, notify your Dynacord representative. The original packaging is the safest container in which to transport products and can also be used to return products for service, if necessary.

4.2 Parts included

| Quantity | Component |
|----------|------------------------------------------|
| 1 | Power amplifier |
| 1 | Mains cord |
| 1 | Euroblock remote connector 5-pole |
| 2 | Euroblock input connector 6-pole |
| 2 | Euroblock output connector 4-pole |
| 4 | Rubber feet |
| 2 | 19"-rack mounting brackets (pre-mounted) |
| 1 | Quick Installation Guide |
| 1 | Safety information |

4.3 Dimensions

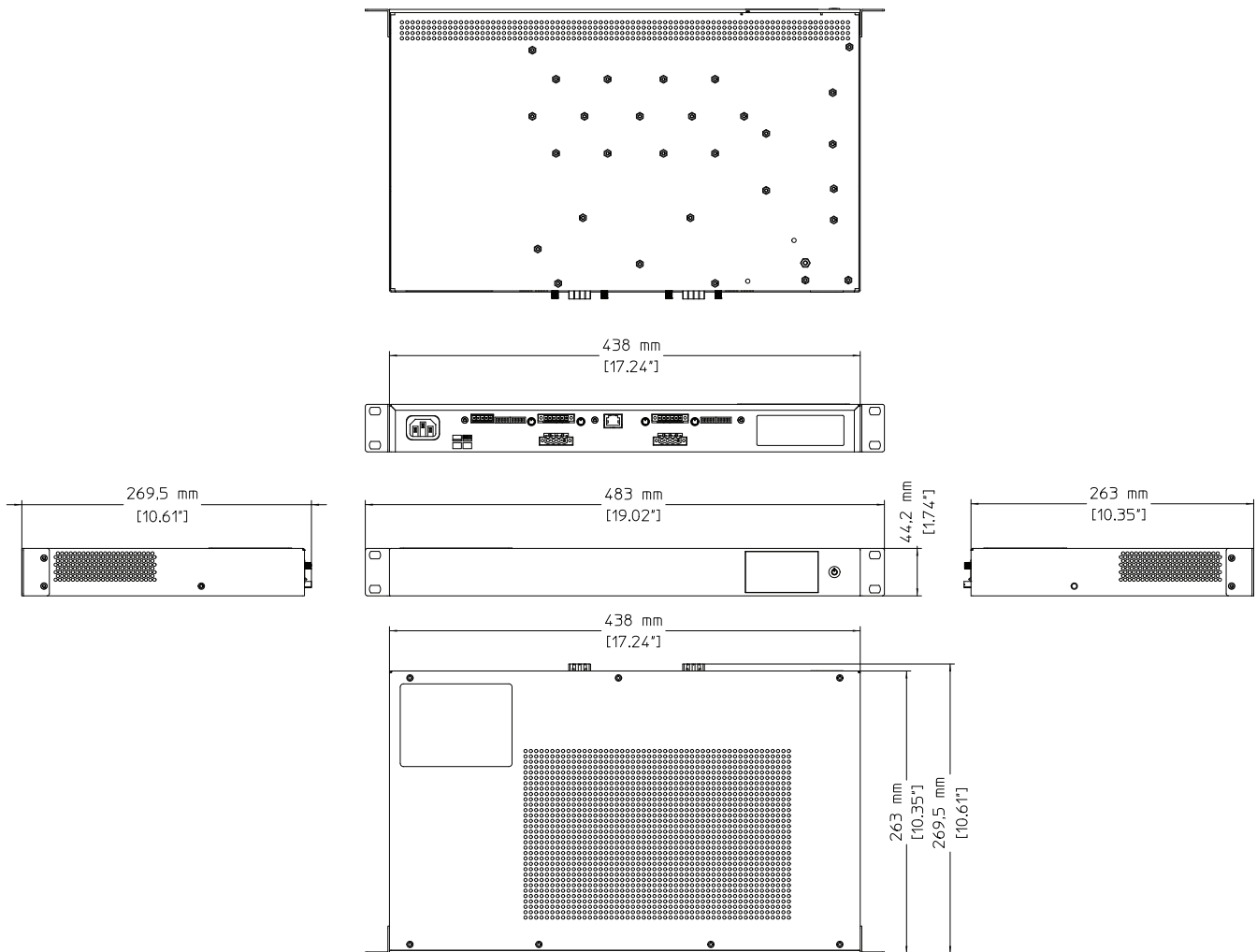

4.4 Mounting and ventilation



Notice!

Before mounting the device, it is recommended to make the required settings. See *Indicators, controls and settings*, page 16.

19"-rack mounting

This power amplifier has been designed for installation in a conventional 19"-equipment rack. Attach the power amp with its frontal rack mount ears using four screws and washers as shown in the illustration.

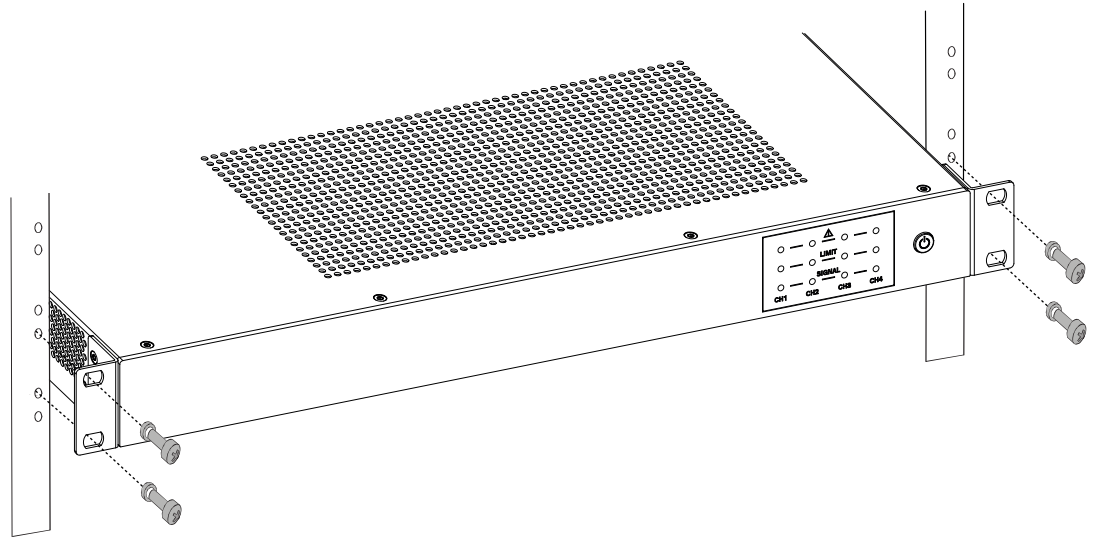

Additionally securing the amplifier by rack rails might be necessary in case you intend to transport the rack. Failure to do so may result in damage to the power amplifier as well as to the rack case.

Table-top use

If you want to use this device outside a 19"-rack on a tabletop, dismount the rack mount ears, and mount the four self-adhesive rubber feet on the bottom of the device.

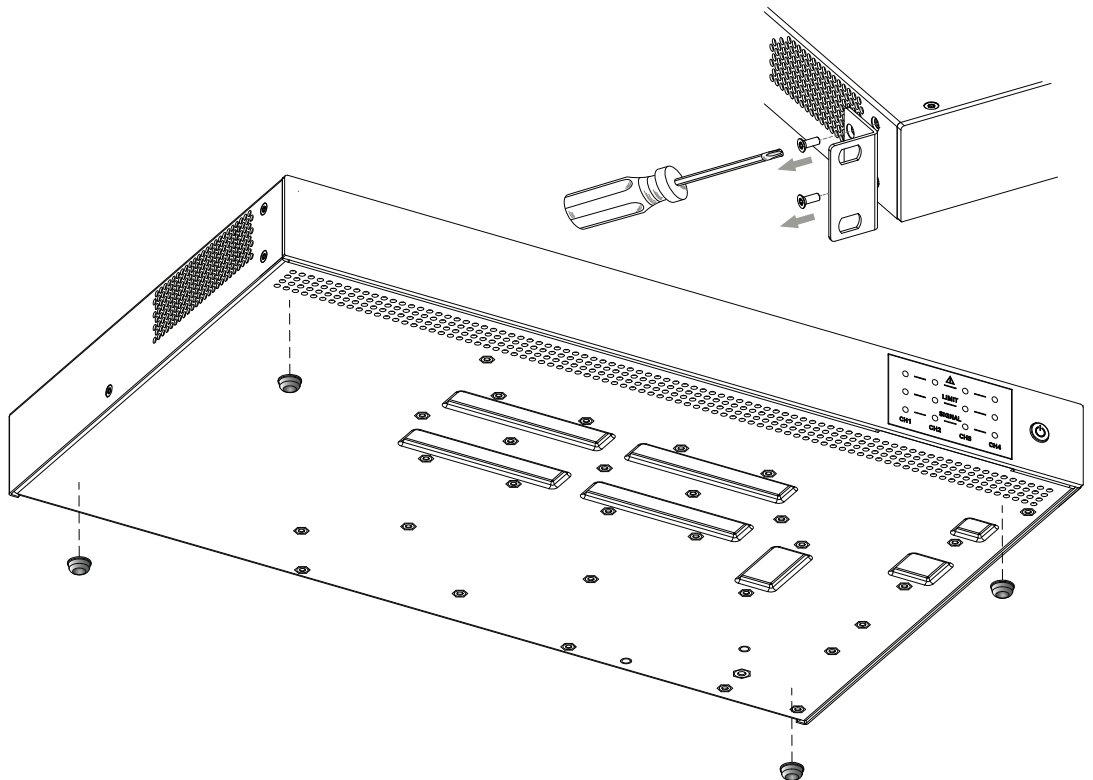

Ventilation

The airflow direction is side-to-rear. In general, setting up or mounting the power amplifier has to be done in a way that fresh air can enter unhindered at the side and exhausted air can exit at the rear. When installing the power amp in a case or rack system, attention should be paid to these details to provide sufficient ventilation.

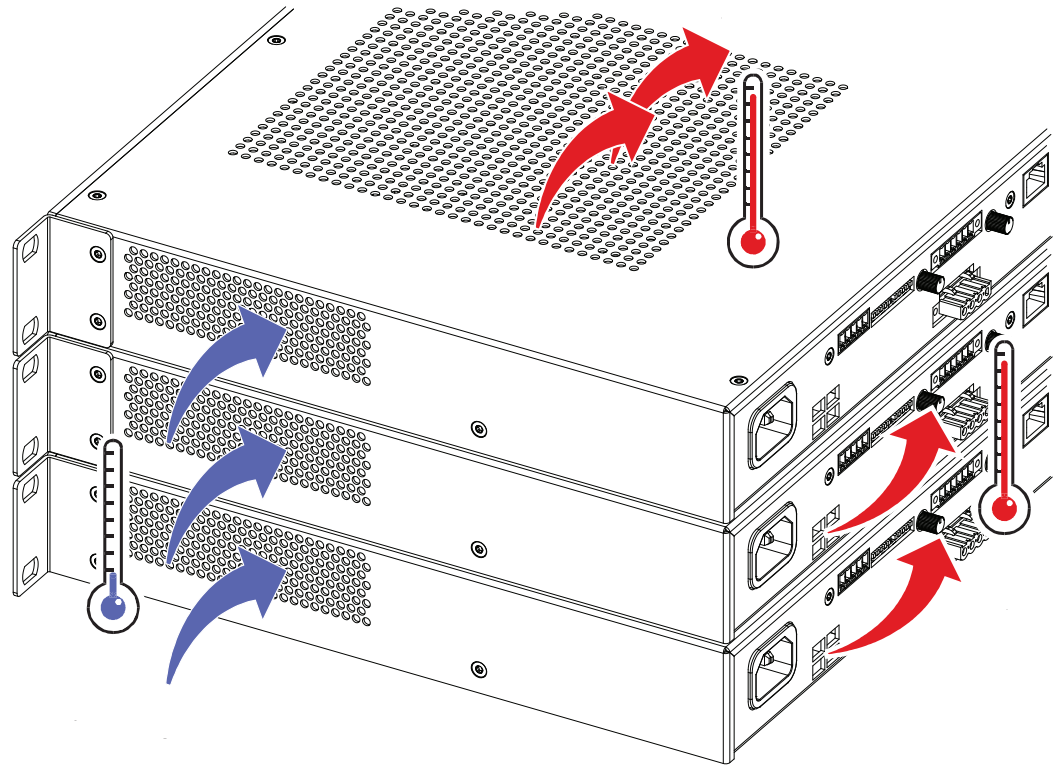

- Allow for an air duct of at least 60 mm between the rear panel of the power amplifier and the inner wall of the cabinet/rack case.
- Make sure that the duct reaches up to the cabinets or the rack case's top ventilation louvers.
- Leave room of at least 100 mm above the cabinet/rack case for ventilation. Since temperatures inside of the cabinet/rack case can easily rise up to 40 °C during operation of the power amp, it is mandatory to bear in mind the maximum allowable ambient temperature for all other appliances installed in the same cabinet/rack case.

For fixed amplifier installations in a device control room that incorporate a central air-cooling system or air conditioners, calculating the maximum heat emission may be necessary. See also *Mains operation and resulting temperature, page 15*.

4.5 Fan cooling

The device is designed for desktop operation without the need to run the fan, using convection cooling. This ensures silent running in most conditions.

The temperature of the power amp's channels are supervised and monitored, as well as the power supply and control unit section. These parameters determine the fan activation to prevent output limiting from occurring.

The fan has two optimized performance levels for low and high and use the same criteria to determine the appropriate level of force cooling required.

The rotation of the fan is supervised. In case of a lock condition where the fan is not rotating, this is indicated with flashing warning LEDs on the front panel and the Fault relay. However, even in such a condition the amplifier will operate without switch-off or reduction if supervised and monitored levels are within the range of silent running parameters.

4.6 Mains operation and resulting temperature

The power drawn from the mains network is converted into output power to feed the connected loudspeaker systems and into heat. The difference between power consumption and dispensed power is called power dissipation (P_d). The amount of heat resulting from power dissipation might remain inside of a rack-shelf and needs to be diverted using appropriate measures.

Mains operation and resulting temperature tables allow the determination of power supply and cabling requirements. The tables are meant as auxiliary means for calculating temperatures inside of a rack-shelf system/cabinet and the ventilation efforts necessary. The column P_d lists the leakage power in relation to different operational states. The column BTU/hr lists the dispensed heat amount per hour.

| V600:4 | U_{mains} [V] (4) | I_{mains} [A] | P_{mains} [W] | P_{out} [W] | P_d [W] (3) | BTU/hr (2) |
|-----------------------------------------|--------------------------------------------------|----------------------------------------------|----------------------------------------------|--------------------------------------------|-------------------------------------|-----------------------|
| Standby | 230 | 0.12 | < 1.0 | 0 | < 1.0 | < 3.4 |
| ecoRAIL mode (incl. Idle) | 230 | 0.23 | < 20.0 | 0 | < 20.0 | < 68 |
| 1/8 Max. Output Power Pink noise (1) | 230 | 1.2 | 125 | 4 x 19 | 49 | 167 |
| 1/3 Max. Output Power Pink noise (1) | 230 | 1.7 | 280 | 4 x 50 | 80 | 273 |
| 1/8 Max. Output Power 1 kHz | 230 | 0.9 | 115 | 4 x 19 | 39 | 133 |
| 1/3 Max. Output Power 1 kHz | 230 | 2.0 | 265 | 4 x 50 | 65 | 222 |

- (1) Pink Noise according IEC 60268-1
- (2) 1 BTU = 1055.06 J = 1055.06 Ws
- (3) P_d = Power dissipation
- (4) The following factors can be used for easy conversion of mains current:
 - 100 V = 2.3
 - 120 V = 1.9
 - 240 V = 0.96



5 Installation

- Indicators, controls and settings, page 16
- Connections, page 21

5.1 Indicators, controls and settings

Front view



| | LED | Indicator description | Color |
|---|-----------------------------------------------------------------------------------|------------------------------|------------------------------------------------------------------------|
| A |  | Device/channel fault (CH1-4) | Red |
| B | LIMIT | Over driven channel (CH1-4) | Yellow |
| C | SIGNAL | Input signal present (CH1-4) | Green |
| D |  | Power On/Off amplifier | Green is ON Blue is ecoRAIL active, or Auto Power Down (APD) active |

Rear view

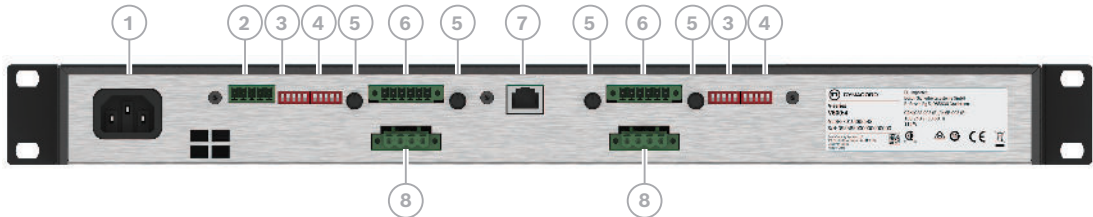

| | Description |
|---|-------------------------------------------------------------------|
| 1 | AC mains input socket |
| 2 | Fault relay (FLT RDY) contacts and REMOTE ON control input socket |
| 3 | AMP MODE (CH1/CH2, CH3/CH4) and DUAL-PARALLEL DIP-switches |
| 4 | SPEAKER EQ (CH1/CH2, CH3/CH4), APD and IN1 to ALL DIP-switches |
| 5 | LEVEL control (CH1-4) |
| 6 | Line level audio inputs socket (CH1/CH2, CH3/CH4) |
| 7 | AMP-LINK "input" RJ45 socket |
| 8 | Loudspeaker OUTPUTS socket (CH1/CH2, CH3/CH4) |

5.1.1 Set the output mode (AMP MODE)

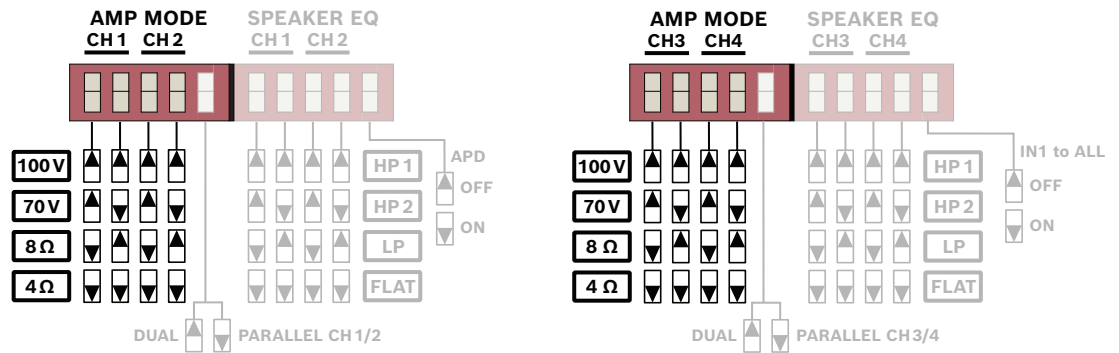

100 Volt and 70 Volt modes

The use of either the 70 V or 100 V modes allow connection of high impedance (HZ) loudspeaker lines without using output transformers. In this case the maximum number of loudspeakers connected to an output channel is only limited by the amplifier channel output power.

It is recommended that this mode should be used if the distance between amplifier and speaker is larger than 50 m of cable distance (approx. 150 ft) and/or a high number of small speakers with transformers are used.

When 100 V or 70 V is selected a 50 Hz High Pass filter is automatically activated to reduce the possibility of loudspeaker transformer saturation to ensure the best performance.

8 Ω mode

In 8 Ω mode the power amplifier reaches rated output power having a load of 8 Ω connected.

4 Ω mode

In 4 Ω mode the power amplifier reaches the rated output power with a single cabinet rated at 4 Ω or two cabinets of 8 Ω each, or up to 4 cabinets of 16 ohms each. These configurations can be driven by each amplifier channel. This mode usually used if multiple speakers with medium or low-power rating are driven in low impedance mode (LZ).

Refer to

- *Indicators, controls and settings, page 16*

5.1.2 Set the input routing (DUAL / PARALLEL / IN1 to ALL)

DUAL and PARALLEL modes are selected for channels 1-2 and separately for channels 3-4, using the DIP switch in the **Up** position for “DUAL” mode or the **Down** position for “PARALLEL” mode. IN1 to ALL affects all channels. If IN1 to ALL is active, it overrides the setting of DUAL/PARALLEL switch.

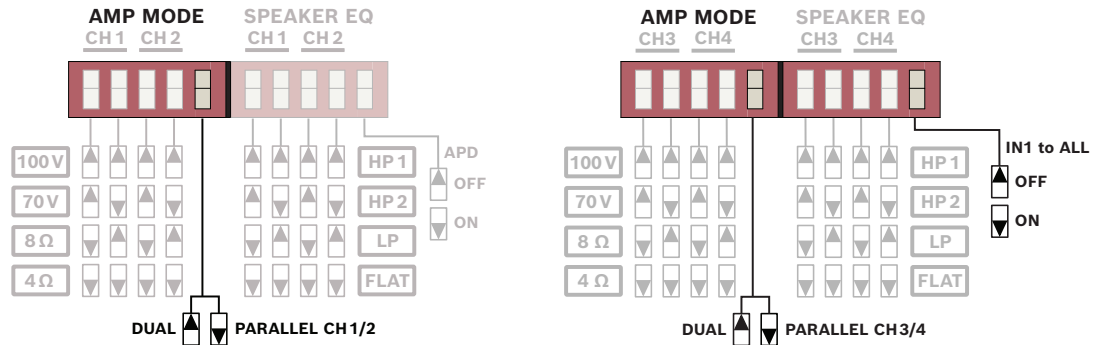

DUAL mode

In DUAL mode, the two adjacent channels controlled via the DIP-switch are completely independent from each other. Using the input level controls on the power amp’s rear panel allows independently adjusting the channels’ amplification.

PARALLEL mode

In PARALLEL mode, the inputs of the channels CH1-2 and/or CH3-4 are directly linked. The audio signal has to be applied to the input connectors of either CH1 resp. CH3. Input level control for CH1 controls CH1 and CH2 at the same time. Respectively level control CH3 affects CH3 and CH4..

IN1 to ALL

IN1 to ALL allows the use of input 1 to be sent to all amplifier channels. IN1 to ALL is configured as either ON or OFF using the IN1 to ALL DIP switch at the rear of the device. Level control CH1 affects the volume of all 4 output channels at the same time.

Refer to

- *Indicators, controls and settings, page 16*

5.1.3

Set the loudspeaker parameters (SPEAKER EQ)

The amplifier's SPEAKER EQ enables the output audio to be optimized to suit particular types of speakers (e.g. subwoofers) or particular environments, allowing some optimization for voice/speech by reducing the low frequency feedback.

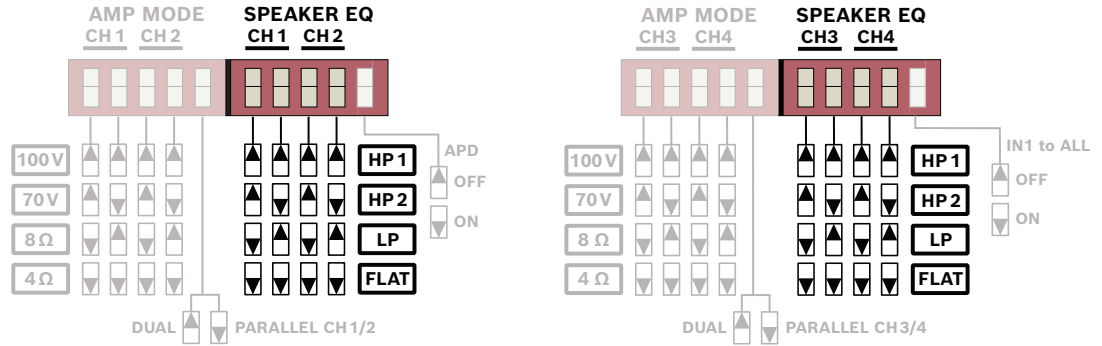

| Mode | CH 1 - 4 switches | | Description |
|------|-------------------|------|--------------------------------------|
| HP1 | Up | Up | High Pass filter 100 Hz @ 24 dB/Oct. |
| HP2 | Up | Down | High Pass filter 150 Hz @ 24 dB/Oct. |
| LP | Down | Up | Low Pass filter 150 Hz @ 24 dB/Oct. |
| FLAT | Down | Down | Full range operation |

- HP1 is optimized for speech and voice announcements as a way to reduce low frequency feedback and microphone handling noise.
- HP2 is useful for use with Mid-High loudspeakers in 2-way speaker systems that contain subwoofers or to further reduce low frequency content from the loudspeakers.
- LP is useful when connected to subwoofers and can be used in combination with HP2.
- FLAT is designed for full range operation and contains a 30 Hz 24 dB/Oct high-pass filter for both 4 Ω and 8 Ω operation or the 50 Hz 24 dB/Oct high pass filter when used in 70/100 V operation.

Refer to

- *Indicators, controls and settings, page 16*

5.1.4 Set the energy safe option (APD)

The APD (Auto Power Down) automatically places the amplifier into a low power standby mode after a period of inactivity when signal, such as a music source, is not present for an extended period.

The threshold level of the APD is -45 dBu* and will automatically activate standby if the signal is constantly below this level for 25 min across all inputs.

The amplifier is woken from APD to full activity by:

- Signal source (music) above -40 dBu threshold.
- Pressing the front panel power button.
- If configured, Remote ON wakes the amplifier from APD through a remote button.

APD is configured as either ON or OFF using the APD DIP switch at the rear of the device.

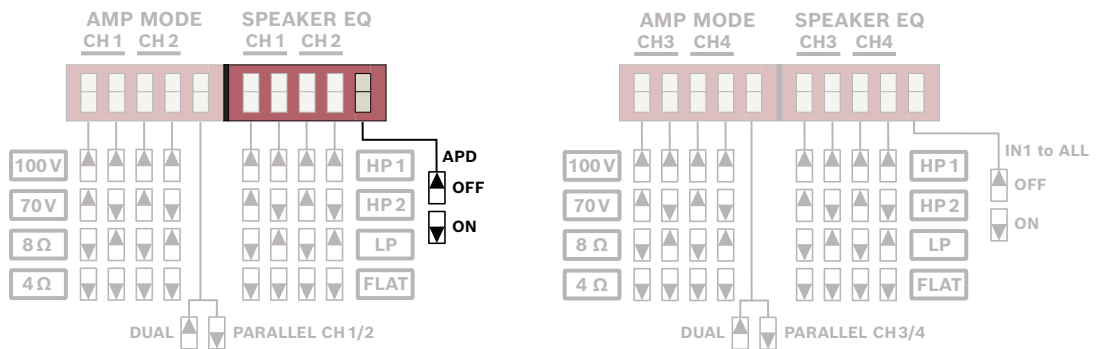

*Activation level depends on several variables including the level controller position. -45 dBu is an estimate based on a 0 dB position of the level control.



Notice!

For activating the device all input channels are monitored, regardless of routing switches or level setting.

Refer to

- *Indicators, controls and settings, page 16*

5.1.5 ecoRAIL

ecoRAIL is a dedicated low-voltage rail supply in the amplifier that significantly reduces power consumption and increases power efficiency. ecoRAIL is permanently configured, so there is no need to activate or set up this function.

5.2 Connections

- *Audio inputs, page 21*
- *AMP-LINK, page 23*
- *Power outputs, page 24*
- *Ready/Fault relay, page 25*
- *Remote on, page 26*
- *Mains power, page 26*

5.2.1 Audio inputs

Audio input connectors are either Euroblock type for 2-channels per connector, or 4-channels via the AMP-LINK RJ45 connector.

Euroblock inputs

Euroblock inputs are electronically balanced. Whenever possible, using balanced audio signal feeds at the input of the power amplifier is always preferred. Unbalanced connections should only be used if the cables are very short and no interfering signals are to be expected in the vicinity of the power amplifier. In this case, bridging the screen (shielding) and the pin of the inverting input inside of the connector is mandatory. Otherwise, a 6 dB drop in level, hum and hiss noise could result. Due to their immunity against external interference sources, such as dimmers, mains connections, HF-control lines, etc., using balanced cabling and connections is always preferable.



Notice!

Euroblock input connectors must be inverted when inserting the connector to the device (screws downwards).

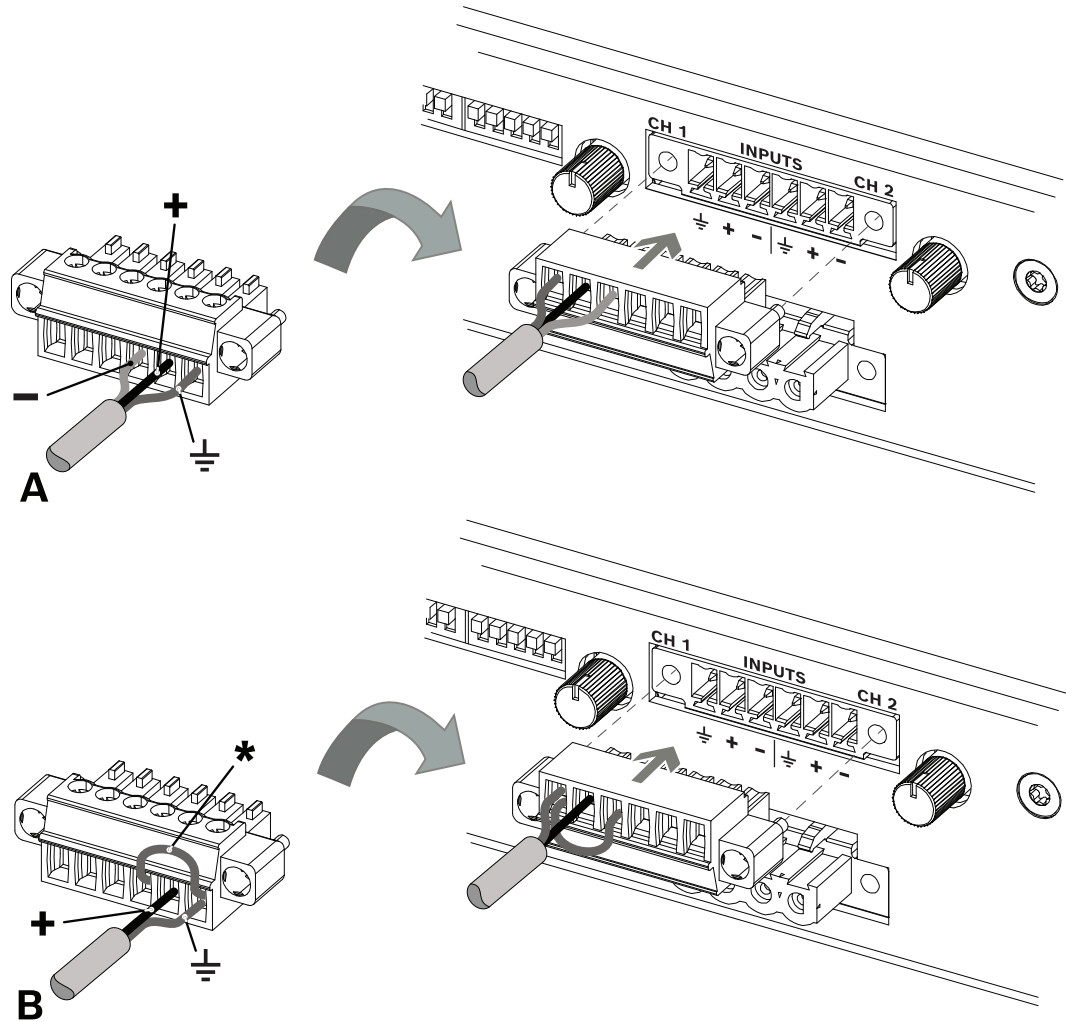

| | |
|---|-----------------------------|
| A | Balanced input connection |
| B | Unbalanced input connection |
| + | Hot |
| - | Cold |
| ⏏ | Shield |
| * | Jumper from cold to shield |

- The pin out is labeled on the rear of the amplifier.

Refer to

- *Indicators, controls and settings, page 16*

5.2.2

AMP-LINK

AMP-LINK functions as either an input of 4 channels via a single cable connection, or as audio output when the Euroblock inputs are in use. This allows one set of inputs from the Euroblock connections to go to another amplifier. AMP-LINK is compatible with any AES72-1E device.

- AMP-LINK is a port with 4 balanced analog audio lines, which makes cabling with compatible devices easy.
- AMP-LINK is compatible with standard CAT5e or CAT6 wiring and it is recommended to use a quality shielded STP cable for increased distances over 5 m to 25 m to reduce audio and signal degradation by maintaining balanced signal.

The wiring of AMP-LINK is below.

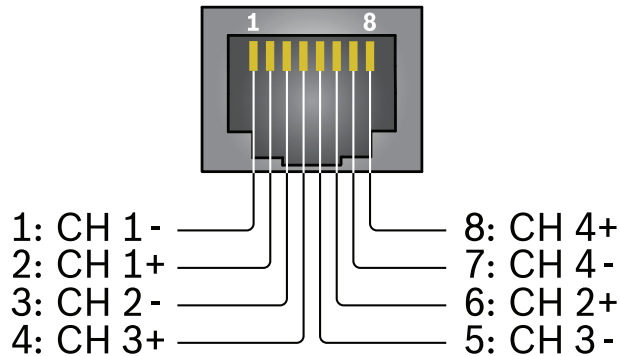

Notice!

The wiring is according to AES72-1E.



Caution!

Do not connect AMP-LINK with Ethernet, CAN bus, Call station, or even PoE powered ports! Noise can occur which may damage speakers or the amplifier.

Refer to

- *Indicators, controls and settings, page 16*

5.2.3 Power outputs

The output connectors are 2 Euroblock type for 2-channels per connector. This allows an easy pre-wiring of the cables outside the rack and a fast - one connection for multiple channels at once, without the danger of wiring errors.



Warning!

It is not allowed to interconnect terminals of different channels!



Caution!

For compliance to UL 62368-1 and CAN/CSA C22.2 No. 62368-1 all loudspeaker wiring must be Class 2 wiring (CL2); this requirement does not apply for compliance to EN/IEC 62368-1.



Caution!

Amplifier outputs may carry output voltages up to 100 V_{RMS}. Touching uninsulated terminals or wiring may result in an unpleasant sensation. The external wiring of these terminals requires installation by an instructed person.

LoZ 4 Ω / 8 Ω application

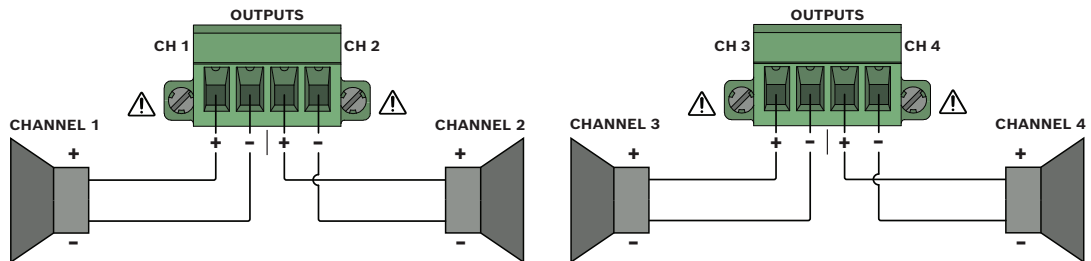

HiZ 70 V / 100 V application (Example channel 1)

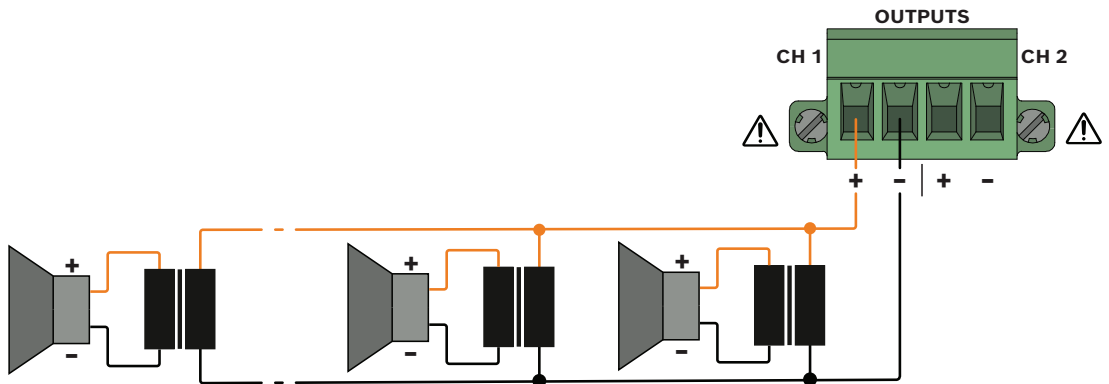

Refer to

- *Indicators, controls and settings, page 16*

5.2.4

Ready/Fault relay

The Ready/Fault relay is a potential free relay toggle for READY or FAULT indication. This allows the amplifier to notify an external device or indicator that the amplifier status is either “RDY” (all is ok) or “FLT” (fault) and may not be functioning correctly. The next table explains the relay setting for the different operation and error modes.

| READY (RDY) / FAULT (FLT) | Description |
|---------------------------|---------------------------------------|
| RDY | Amp active, all channels on |
| FLT | APD is activated or device is not on |
| FLT | One or more channels in Protect state |
| FLT | Internal error, e.g. fan blocked |

*) RDY/FLT: Indicates the closed contact.

Figure A shows the FLT (fault) condition, figure B shows the RDY (all is ok) condition.

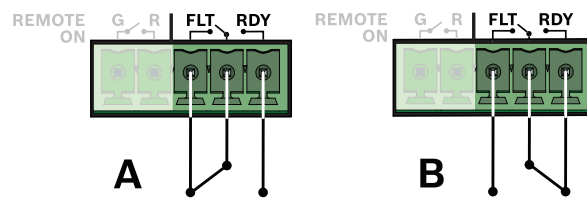

Refer to

- *Indicators, controls and settings, page 16*

5.2.5

Remote on

REMOTE ON provides a simple way to remotely power-on/off the power amplifier. REMOTE ON overrides front panel power button when activated.

This can be used by an external device or a simple switch that can be located away from the amplifier for convenience.

- Leaving the pins of REMOTE ON socket “open” (nothing connected) the device works with the front panel power button.
 - See figure A below.
- When connecting the pins, the device is enforced to power on. This overrides the operation of the front power button.
 - See figure B below.

To configure the amplifier so that users cannot turn off the device (avoiding user error), simply wire bridge the two pins together, then the front panel power button is permanently overridden.

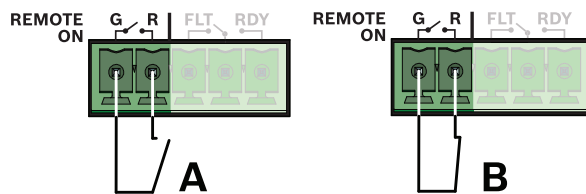

Refer to

- *Indicators, controls and settings, page 16*

5.2.6

Mains power

The power amplifier receives its power supply via the MAINS IN connector. Only the provided power cord may be used. The amplifier is equipped with a wide range power supply. Relevant technical data regarding mains power consumption can be found on the product label on the rear-side of the amplifier.



Notice!

When power is restored, the device will continue in its last known mode of operation.



Caution!

During installation, always separate the power amplifier from the mains socket! Only a correctly installed and grounded wall mains outlet must be used.



Caution!

The front power button doesn't disconnect the device from mains. The only way to switch-off mains entirely is to remove the power plug.

Refer to

- *Technical data, page 31*
- *Indicators, controls and settings, page 16*

6 Operation after installation

6.1 Power on

The device can be activated by pushing the power button on the front panel. Speaker system switch-on is delayed by approximately three seconds via output relays, effectively suppressing any possible power-on noise, which otherwise might be heard through the loudspeakers.

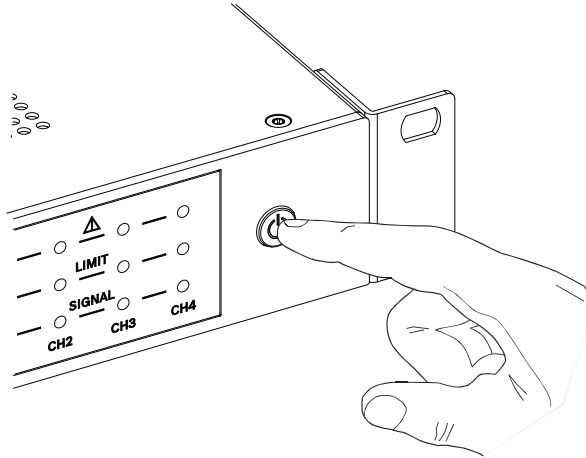

- See also *Remote on*, page 26.

6.2 Input level control

Adjustment of amplifier to source.

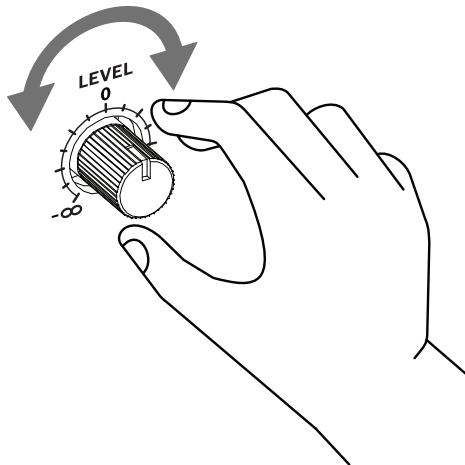

- Default is middle position. Full clockwise spends additional 6 dB to drive the amplifier even from weak sound sources.

The level control is assigned with the physical input, not the output channels. If routing PARALLEL or IN1 to ALL is used, the level control is same for all 4 channels.



Notice!

The level control of the unused input is ineffective. If however independent level control is desired, the DUAL routing should be used instead and the inputs wired as parallel.

Refer to

- *Indicators, controls and settings*, page 16

7 Troubleshooting

| Problem | Possible cause | Solution |
|---------------------------------------------------------------------------------------------|-----------------------------------------------------------------------------------------------------------------------------------------------------------------------------------------------------------------------------------------------------------------------------------------|------------------------------------------------------------------------------------------------------------------------------------------------------------------------------------------------------------------------------------------------------------------------------------------------------------------------------------------------------------------------------------------|
| Amplifier does not turn on and power LED is not illuminated. | Power (plug) disconnected or the power source is giving insufficient power to the device. | Ensure power cord is securely connected to device and check the power from the mains. |
| Power button LED is continuously blinking. | Start-up fault. | Contact service agent. |
| No audio signal (no front panel LED indication). | <ol style="list-style-type: none"> 1) Audio input cable has come loose or has not been properly plugged in. 2) Input source is not sending signal or sufficient signal. 3) Input level is turned down. | <ol style="list-style-type: none"> 1) Check that the cables for any damage. Check that the cables are installed and wired correctly. Check that the wires are secured inside the connector, and the connector is fully plugged in and seated securely to the amplifier. 2) Ensure that the input is turned up. |
| No audio is coming out of the speakers, but the input LED indication shows there is signal. | <ol style="list-style-type: none"> 1) Output speaker cable has come loose or has not been properly plugged in. 2) Maybe there is a pilot tone present. | <ol style="list-style-type: none"> 1) Check that the cables for any damage. Check that the cables are installed and wired correctly. Check that the wires are secured inside the connector, and the connector is fully plugged in and seated securely to the amplifier. 2) Pilot tone will usually not be audible, but the amplifier is still working correctly. |
| Audio sounds distorted. | <ol style="list-style-type: none"> 1) Input level is too high or too low. 2) Clipping of input stage. 3) Music source is of poor quality. 4) The amplifier is being overdriven by exceeding the max. output allowed (i.e. drained powerTANK). | <ol style="list-style-type: none"> 1) Ensure that the source level is not too high or too low. This could mean re-adjusting the level on the amplifier. 2) Check the quality of source material. 3) Turn down or consider a bigger amplifier. |
| Audio sounds very muffled or lacks low frequencies. | Incorrect speaker settings are activated (e.g. LP used with a full range speaker). | Adjust the speaker settings on the rear of the device and ensure that the settings match they types of speakers used. |

| Problem | Possible cause | Solution |
|------------------------------------------------------------------------------------------------------------------|-------------------------------------------------------------------------------------------------------------------------------------------------|--------------------------------------------------------------------------------------------------------------------------------------------------------------------------------------------------------------------------------|
| | | See <i>Set the loudspeaker parameters (SPEAKER EQ)</i> , page 19. |
| Weak sound output, but with no fault indications. | Incorrectly wired input connectors. | Ensure that the input cables are correctly match to the polarity of the source (i.e. wired correctly). See <i>Audio inputs</i> , page 21. |
| Hum and hiss noise. | Interference on inputs due to unbalance cables or incorrect connections. | Suggest using balanced input cable wiring. See <i>Audio inputs</i> , page 21. |
| Fault LED on the amplifier channel is indicating solid red. | 1) Speaker cable has a short or the cable is damaged. 2) incorrect AMP MODE selected. 3) Internal amplifier channel malfunction. | 1) Check or replace speaker cables and ensure that connections are wired correctly. 2) Select the appropriate AMP MODE for your speakers. See <i>Set the output mode (AMP MODE)</i> , page 17. 3) Contact service agent. |
| APD has been activated, but the amplifier is not going into standby mode. | 1) Possible unintended signal or interference on the input. 2) Signal could be present on an unused channel from the desired signal routing. | Check that there are no unintended signals on any inputs (including ground loop interference). |
| Amplifier does not wake up from APD. | Input source level is too low. | Ensure that the input source is active and delivering sufficient signal to the amplifier. |
| ecoRAIL is not activating as expected. | Volume is set too high. | Lower the volume, or consider more sensitive speakers which will deliver higher volume with ecoRAIL engaged. |
| Amplifier is working, but all the red LEDs are flashing every 2 seconds and the relay is showing a fault status. | Fan error. | Check blockages or if something is caught in the fan. |
| Output power is reducing, and LIMIT LED is illuminating. | Amplifier is under extreme thermal conditions, well beyond operating specifications of 45 °C. | Consider changing the location of the amplifier and check that there is sufficient airflow around the amplifier. |

8 Maintenance

This product has been designed to operate without problems for a long period of time, with a minimum of maintenance.

In order to guarantee trouble-free operation periodically:

- Clean all units with a damp, lint-free cloth; never use water or chemicals.
- Vacuum the air vents to ensure good ventilation.
- Check all cable connections for corrosion and the screw terminals to make sure that they have not become loosened.
- Check the ground (PE) connection of the system components.

9 Technical data

Electrical

| Output power | 4 Ω | 8 Ω | 70 V | 100 V |
|------------------------------------------------------------------------------------|----------------------------------------------------|-----------------------|----------------------------------------------------|----------------------|
| Rated output power ¹ | 4 x 150 W | | | |
| Maximum output power per channel (power sharing) ¹ at minimum impedance | 500 W | 600 W | 500 W | 600 W |
| Total rated output power ¹ | 600 W | | | |
| Number of channels | 4 | | | |
| Output voltage rated output power | 24.5 V _{RMS} | 34.6 V _{RMS} | 70.7 V _{RMS} | 100 V _{RMS} |
| Maximum output voltage | 40.0 V _{RMS} | 56.0 V _{RMS} | 70.7 V _{RMS} | 100 V _{RMS} |
| Rated impedance per channel | 4 Ω | 8 Ω | 33.3 Ω | 66.7 Ω |
| Minimum impedance per channel | 2.6 Ω | 4 Ω | 10 Ω | 16.7 Ω |
| Amplifier | 4 Ω | 8 Ω | 70 V | 100 V |
| Nominal Gain (+6 dBu input sensitivity, LEVEL 0 dB) | 24.0 dB | 27.0 dB | 33.2 dB | 36.2 dB |
| Maximum Gain (0 dBu input sensitivity, LEVEL +6 dB) | 30.0 dB | 33.0 dB | 39.2 dB | 42.2 dB |
| THD+N (1/8 rated output power, 1 kHz) | < 0.1 % | | | |
| Crosstalk (ref. 1 kHz, 12 dB below maximum) | < -70 dB | < -75 dB | < -90 dB | < -95 dB |
| Frequency Response ² (ref. 1 kHz, analog in to speaker out, -3 dB) | HP: 30/100/150 Hz to 20 kHz LP: 30 Hz to 150 Hz | | HP: 50/100/150 Hz to 20 kHz LP: 50 Hz to 150 Hz | |
| Damping Factor (30/50 Hz to 1 kHz, ref. to rated impedance) | > 80 | > 160 | > 500 | > 1000 |
| Output Stage Topology | Class D, fixed frequency | | | |
| Signal to Noise Ratio (A-weighted, ref. to rated output power, LEVEL 0 dB) | > 98 dB | > 100 dB | > 101 dB | > 103 dB |
| Output Noise (A-weighted, LEVEL 0 dB) | < -68 dBu | < -67 dBu | < -62 dBu | < -61 dBu |

| Connectivity | |
|------------------------------------------|--------------------------------------------------------------------------------------------------------------------------------------------------------|
| Analog Audio Input | |
| Type | 2 x 6-pin Euroblock, 3.81 mm, male, parallel 1x RJ45 AMP-LINK |
| Maximum input level (LEVEL 0 dB) | +18 dBu |
| Input impedance, active balanced | 20 k Ω |
| Mains Input | IEC C14 |
| Loudspeaker output | 2 x 4-pin Euroblock, 5.08 mm, female |
| Control Port | |
| Type | 1 x 5-pin Euroblock, 3.81 mm, male |
| REMOTE ON | Remote On / Standby contact (overrides power button on front panel) |
| READY/FAULT | Galvanic isolated relay, max. 30 V _{DC} / 500 mA _{DC} |
| General | |
| Signal processing | Input Routing, HPF 24 dB/Oct., LPF 24 dB/Oct., Flat, Peak Limiter |
| Power requirements | 100 V to 240 V, 50 Hz to 60 Hz AC |
| Power consumption | |
| Consumption at 1/8 rated output power | 115 W |
| Idle mode (ecoRAIL with no input signal) | < 20 W |
| Standby mode (APD active) | < 1 W |
| Power supply topology | Switching power supply with power factor correction |
| Protections | Audio limiters, high temperature, DC, HF, short circuit, back-EMF, peak current limiters, inrush current limiters, mains over/under voltage protection |
| Front status LEDs | Signal, limit, fault LEDs per channel; power LED |

Environmental

| Climatic conditions | |
|----------------------------|----------------------------------------------------------------------------------------------------------------------------------------------------------------------------------------------------------------|
| Cooling concept | Convection cooling in tabletop application and rack application with spacing between units. Forced cooling (side to rear) in rack application without spacing between units and in extreme thermal conditions. |
| Ambient temperature limits | -5 °C to +45 °C (+23 °F to +113 °F) |
| Altitude (operating) | -500 m to +5000 m (-1614 ft to 16404 ft) |

Mechanical

| Enclosure | |
|--------------------------------------------------|--------------------------------------------------|
| IEC Protection Class | Class I (grounded) |
| Dimensions (HxWxD) With 19" mounting brackets | 44.2 x 483 x 269.5 mm (1.74 x 19.2 x 10.6 in) |
| Weight | 3.6 kg (7.9 lb) |

¹⁾ Test signal for max. output power according IHF-A-202 (Dynamic-Headroom, burst 1 kHz / 20 ms on / 480 ms off / low level -20 dB)

²⁾ Selectable via Speaker EQ.

10

Approvals

| Regulatory areas | |
|-------------------------|---------------------------------------------------------------------------------------------------------|
| Safety | EN/IEC/CSA/UL 62368-1 |
| Immunity | EN 55035, EN 61000-4-11 |
| Emissions | EN 55032, EN 61000-3-2, EN 61000-3-3, ICES-003, e-CFR Title 47 Chapter I Subchapter A Part 15 Subpart B |
| Environment | EN/IEC 63000 |

11 Block diagram

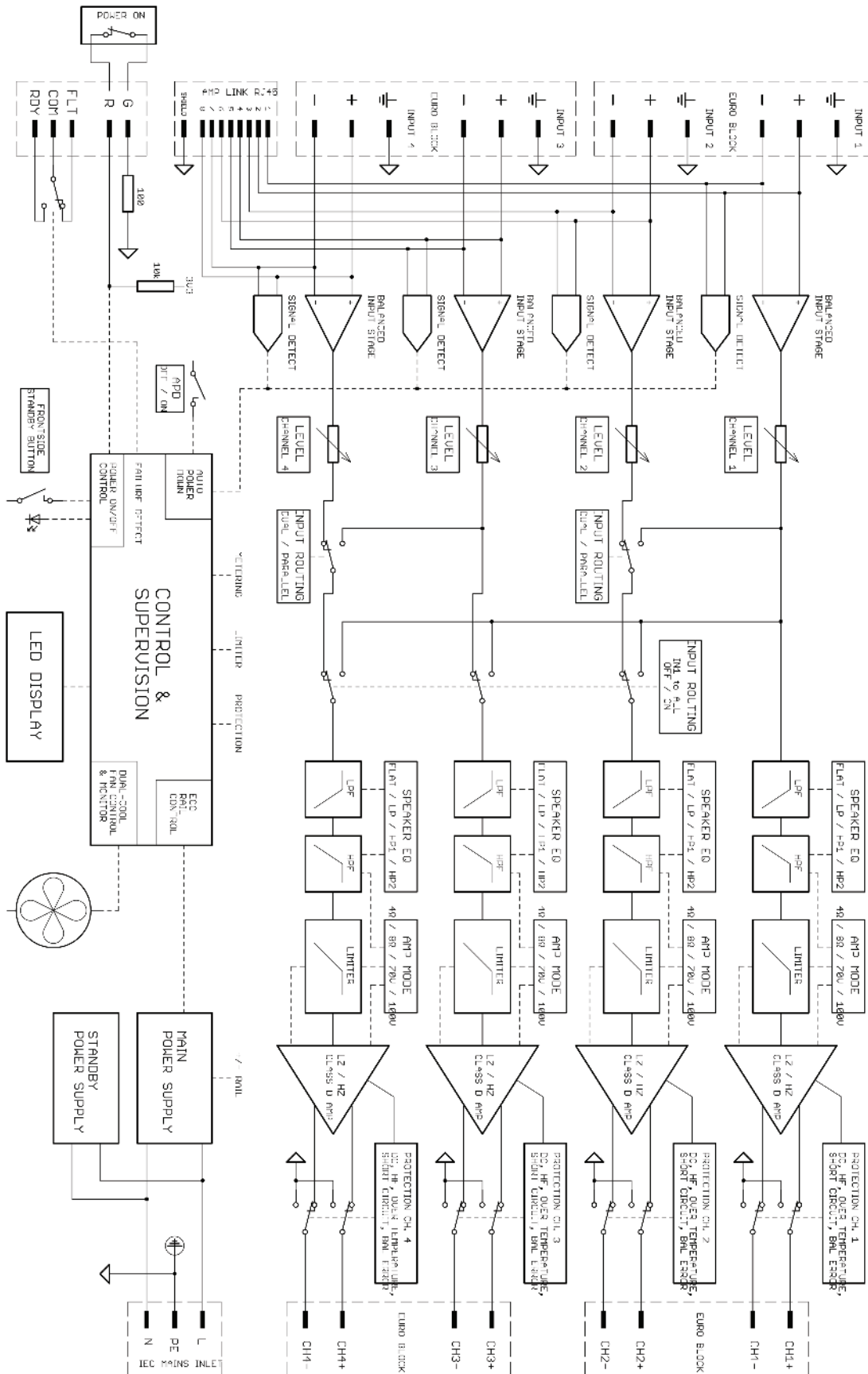

12

Support and academy



Support

Access our **support services** at www.boschsecurity.com/xc/en/support/.

Bosch Security and Safety Systems offers support in these areas:

- [Apps & Tools](#)
- [Building Information Modeling](#)
- [Warranty](#)
- [Troubleshooting](#)
- [Repair & Exchange](#)
- [Product Security](#)



Bosch Building Technologies Academy

Visit the Bosch Building Technologies Academy website and have access to **training courses**, **video tutorials** and **documents**: www.boschsecurity.com/xc/en/support/training/

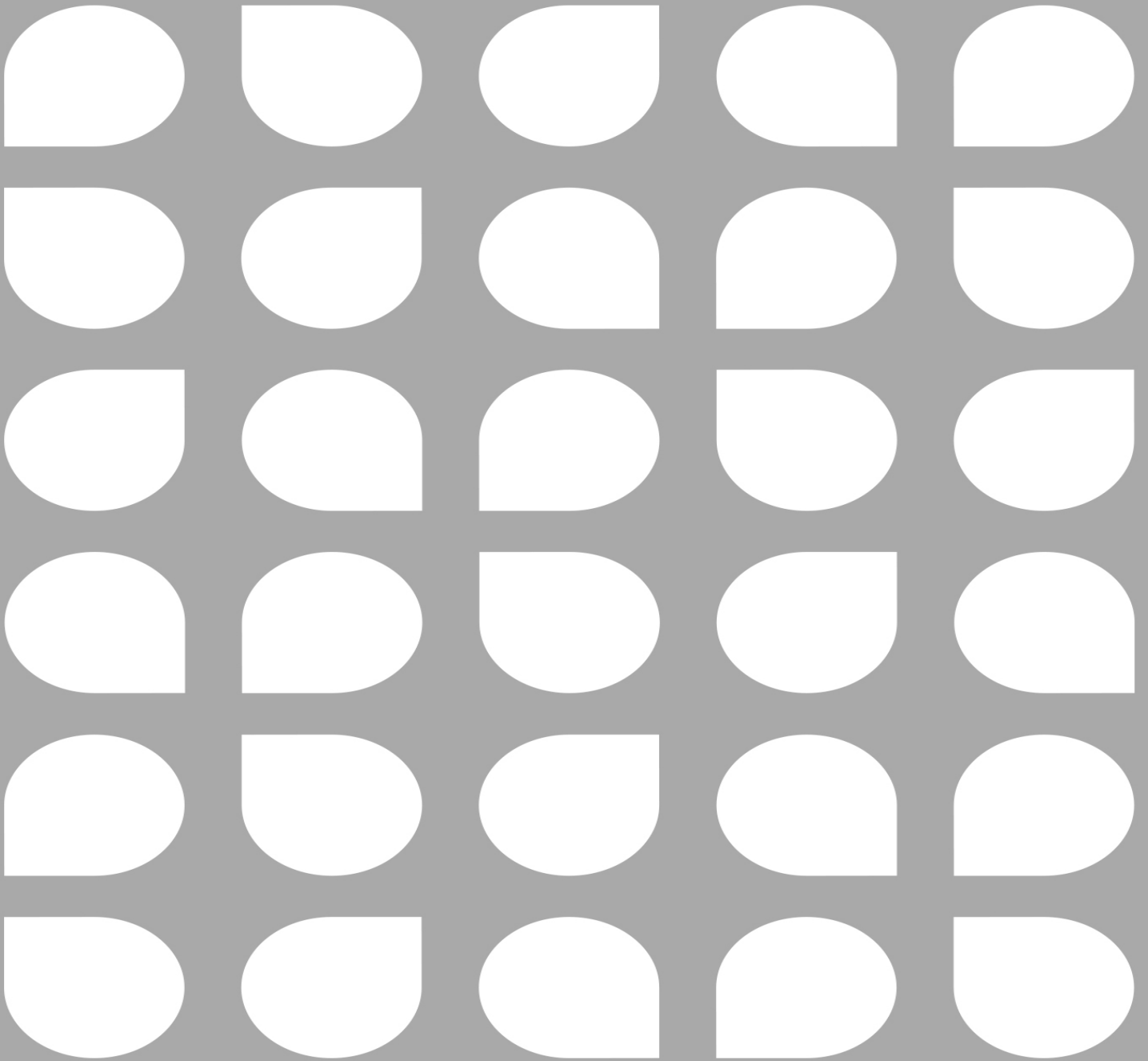

Bosch Security Systems B.V.

Torenallee 49
5617 BA Eindhoven
Netherlands

www.boschsecurity.com

© Bosch Security Systems B.V., 2023