



AcousticCoverage™ Series

AC-C8T

Two-way, ceiling mount
loudspeaker

Features

- High quality transducers provide exceptional clarity through the critical voice range.
- Improved musicality often not seen in typical BGM class products.
- Ported baffle for increased low frequency extension down to 52 Hz.
- Low saturation 70/100V transformers with 8 ohm bypass.
- 4-pole Euroblock connector eases system wiring.
- Advanced voicing via QSC Intrinsic Correction™, applied using the Q-SYS™ Platform or CXD Series amplifier platforms.
- White (RAL 9010) with UV inhibitors to match complimenting QSC product families.
- Complete EASE, CF2, CAD, & BIM information available online.



Wide Area Paging · Background Music · Distance Conferencing Reinforcement · Healthcare Facilities · Concourses · Transportation Terminals · Ancillary Support in Larger Systems

The QSC AcousticCoverage™ Series AC-C8T is a ceiling-mounted 8-inch two-way loudspeaker with 70/100V transformer, suitable for a wide variety of audio/video conferencing reinforcement, voice paging and background music applications.

AcousticCoverage™ Series is designed to offer integrators a cost-effective solution for applications where voice reinforced coverage is of primary concern, while providing improved musicality often not seen in typical BGM class products.

The high quality 8-inch polypropylene cone transducer with butyl rubber surround and the sensitivity matched coaxially mounted .86-inch silk dome tweeter offers pristine clarity through the critical vocal range for increased speech intelligibility. With 100 degrees of conical coverage, the AC-C8T reduces the number of loudspeakers required for even coverage in low ceiling applications.

The easy-to-install blind mount assembly features a ported baffle which optimally tunes the plated steel backcan for added musicality, creating low frequency extension down to 52 Hz. To maintain this frequency response, the AC-C8T utilizes a 60-watt low-saturation and low-loss 70/100V transformer with varying selectable taps, including an 8Ω bypass. The rotary tap selector switch is accessible under the painted steel grille.

To further enhance performance and speed of install with optimum result, advanced voicing via QSC Intrinsic Correction™ techniques are obtainable using the Q-SYS™ Platform, or CXD Series amplifiers for a complete QSC systems solution.

Installers will appreciate the 4-pole Euroblock connector for loop-thru wiring, located under a quick access swivel plate. Eliminating the termination hassles of star topology wiring designs, the generous Euroblock of the AC-C8T can accept four 18AWG pairs.

A safety tether tab is affixed to the adjustable conduit clasp plate for seismic-sensitive installations. C-ring and tile rails are included with each pair packed assembly, complete with joining screws and cut-out template.

The AC-C8T baffle and grille are QSC standard white (RAL 9010) to match complementing QSC product families and includes UV inhibitors to prevent discoloration over time. The AC-C8T may also be painted to match any décor.

For your system integration needs, complete EASE, CF2, CAD, and BIM files are available for download at QSC.com.

AC-C8T Details

Beamwidth:

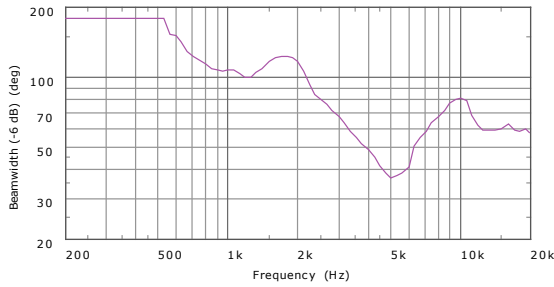

Impedance / Frequency Response:

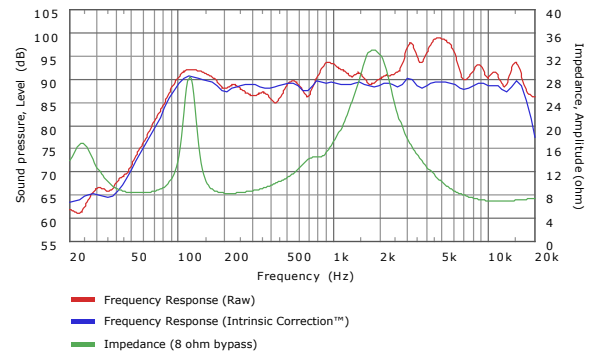

Dimensions:

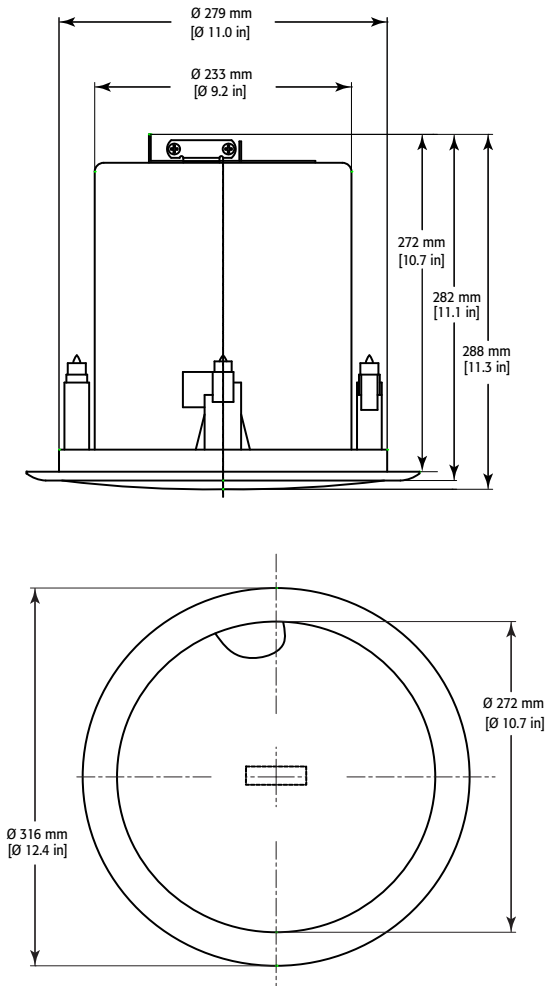

Specifications:

System Details	AC-C8T
Effective Frequency Range ⁽¹⁾	52Hz – 20kHz
Rated Noise Power / Voltage ⁽²⁾	80W / 25.3V (rms)
System Sensitivity ⁽³⁾	89dB SPL
Coverage Angle (-6 dB)	100° (500 Hz - 5 kHz)
Maximum Continuous SPL ⁽⁴⁾	108dB
Maximum Peak SPL ⁽⁴⁾	114dB
Rated Bypass Impedance	8 ohms
Transformer Taps	70 V: 60, 30, 15, 7.5, 3.8 watts 100 V: 60, 30, 15, 7.5 watts 8 ohm bypass
HF Transducer	22 mm [.86 in] silk dome tweeter, coaxially mounted
LF Transducer	210 mm [8 in] Polypropylene cone with butyl rubber surround
Input Connector Type	Euroblock connector with parallel output terminals
Baffle Material	Painted ABS polymer
Grille Material	Painted steel
Back Can Material	Plated steel
Testing	Listed UL1480, UL2043 safe for use in air handling space
Net Weight	5.2 kg [11.5 lb]
Product Dimensions	316 x 288 mm [12.4 x 11.3 in]
Cut-Out Dimensions	285 mm [11.2 in]
Ceiling Capture Thickness	6 - 38 mm [0.25 - 1.5 in]
Shipping Weight	13.3 kg [29.3 lb] (pair packed)
Shipping Dimensions	743 x 381 x 381 mm [29.3 x 15 x 15 in]
Included Accessories	Rails & C-ring for ceiling tile installation

⁽¹⁾ Half-space, -10 dB from on-axis sensitivity

⁽²⁾ IEC60268-1 noise signal for 2 Hrs

⁽³⁾ On-Axis, free-field sensitivity, 2.83V, 1 m

⁽⁴⁾ Calculated from rated noise voltage and sensitivity

As part of QSC's ongoing commitment to product development, specifications are subject to change without notice.

QSC®

1675 MacArthur Boulevard • Costa Mesa, CA 92626 • Ph: 800/854-4079 or 714/957-7100 • Fax: 714/754-6174

© 2016 QSC, LLC all rights reserved. QSC and the QSC logo are registered trademarks of QSC, LLC in the U.S. Patent and Trademark office and other countries. AcousticCoverage, Intrinsic Correction and Q-SYS are trademarks of QSC. All other trademarks are the property of their respective owners. Patents may apply or be pending.



please recycle