



AD-C81Tw

AcousticDesign™ Ceiling Mount Subwoofer

Features

- 8" polypropylene cone woofer
- Large port area for extended low-frequency performance
- Defeatable passive 120 Hz low-pass filter with impedance compensation
- 100 watts continuous power handling, 400 watts peak
- 70/100 V multitap transformer with 8 ohm bypass
- C-ring and tile rails included
- Side cable entry

The AcousticDesign Series of installation loudspeaker products from QSC expands with the new AD-C81Tw ceiling mount subwoofer system. Designed to supplement audio systems with low-frequency extension, the new AD-C81Tw is acoustically matched to the entire AD Series. Rated for 100 watts continuous power handling and able to take up to 400 watt peaks, the AD-C81Tw is a great compliment to any of the ceiling mount or surface mount AD Series models.

The 8" woofer is equipped with a polypropylene cone for protection in humid environments. The driver features a synthetic rubber surround and works optimally with the large port to provide excellent low frequency extension below 40 Hz without undesirable port turbulence. This highly efficient design measures 92 dB SPL sensitivity. The AD-C81Tw has a built in passive low-pass filter set at 120 Hz. The filter is defeatable from the front baffle to allow the use of outboard crossovers.

The baffle and mounting tabs are molded from high-impact polystyrene. The rear enclosure is heavy gauge, powder coated steel. The attractive aluminum grille is backed with an acoustically transparent white cloth. The input cup is mounted on the side of the enclosure to reduce the amount of vertical clearance necessary to install the speaker. The input cup cover features a conduit attachment point plus an additional knockout for daisy-chain wiring. Input signal connection is made with a high temperature resistant ceramic screw terminal for compliance with European safety standards.

The AD-C81Tw is factory shipped with C-rings and tile rails for installation. New construction rings (ADC-NCS) and mud rings (ADC-MRS) are also available separately. The AD-C81Tw is equipped with a 70/100 V transformer with multiple taps and an 8 ohm bypass.



Specifications

Configuration	Ceiling subwoofer, ported
Low-frequency Transducer	8" (20 cm) weather resistant, polypropylene cone woofer, rubber surround
Frequency Range ¹	
Frequency Response (-6 dB)	39 Hz – 184 Hz
Useable Frequency Range (-10 dB)	28 Hz – 208 Hz
Filter	120 Hz low-pass, passive, bypassable
Maximum Output ²	
Calculated Peak Output	118 dB SPL
Calculated Continuous Output	112 dB SPL
Nominal Impedance	8Ω
Power Rating	
RMS Power Handling ³	100 W (100 hours IEC)
Recommended Max Amp Power	200 W RMS
Sensitivity	92 dB, 2.83 V, 1 m, free space (4π)
Transformers	
Type	Custom low distortion laminated core, wide bandwidth design
Taps	70 V: 60, 30, 15, 7.5 W / 100 V: 60, 30, 15 W / 8Ω selected by switch
Environmental	Exceeds Mil Spec 810 for humidity, salt spray and dust; IEC 60529 IP-X3 splash rating
Agency Rating	Listed UL1480, UL2043 safe for use in air handling spaces; Transformer is Listed UL1876; Compliant BS/EN 60849 safety standards
Enclosure	
Material	Injection molded, high impact polystyrene baffle on a steel enclosure
Finish	White (paintable)
Grille	Painted aluminum
Connectors	Ceramic block or 4-pin Euro terminals in fire protective sub-chamber
Mounting Hardware	Rails and C-ring for ceiling tile installation
Weight - Net/Shipping	20 lb (9.1 kg)/28 lb (12.7 kg)
Available Accessories	ADC-MRS Mud ring bracket • ADC-NCS New construction bracket



1) All frequency ranges specified refer to measured free field response.
 2) Calculated SPL at 1m, (free space, 4π), speaker operating at rated RMS power with pink noise within specified frequency range
 3) Maximum input power tested in accordance with IEC 268-5 recommendations, 50 Hz – 20 kHz band limiting, 6 dB signal crest factor.

AD-C81Tw

Dimensions | Frequency Response

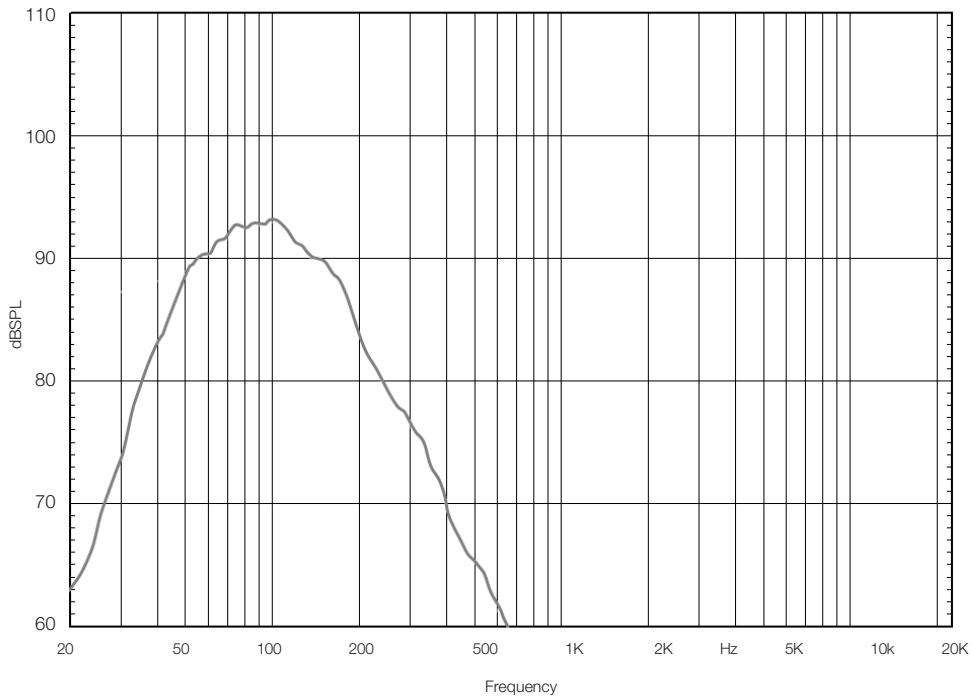
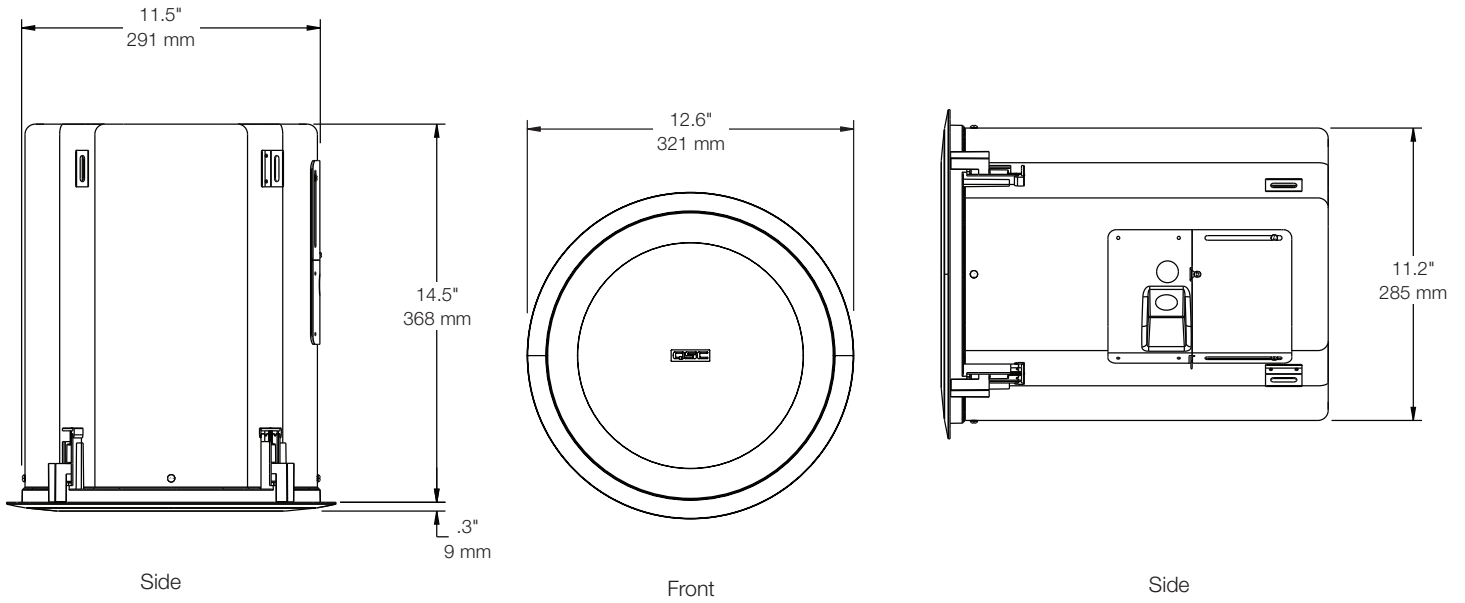

Specifications subject to change without notice.



©2020 QSC Audio Products, LLC. All rights reserved. QSC and the QSC logo are registered trademarks of QSC Audio Products, LLC in the U.S. Patent and Trademark office and other countries. AcousticDesign is a trademark of QSC Audio Products, LLC. All other trademarks are the property of their respective owners. Patents may apply or be pending.

1675 MacArthur Boulevard • Costa Mesa, CA 92626 • Ph: 800/854-4079 or 714/957-7100 • Fax: 714/754-6174

QSC
qscaudio.com