



## AcousticDesign™ Series AD-P.SUB

6.5-inch dual voice coil, small format  
pendant subwoofer

### Features

- Consistent tonal characteristics across the entire AcousticDesign Series for surface, ceiling, and pendant applications
- Refined depth and clarity even at low volume settings
- Mix-and-match match capable, any subwoofer with any satellite in the AD Series SUB/SAT line
- Dual voice coil for improved thermal dissipation and higher output
- Low-saturation and low-loss 70 / 100 V transformers with 4  $\Omega$  bypass
- Snap-fit magnetic grill
- 4x built-in high-pass filtered outputs
- Locking 4-pole Euroblock connectors
- 2x quick link cable assemblies and slip-lock fasteners supplied
- Removable logo
- Intrinsic Correction™ voicings available via MP-M Series mixers and the Q-SYS Platform, including CXD-Q Series amplifiers
- Available in black (RAL 9011) or white (RAL 9010)
- Complete EASE, CF2, CAD, & BIM information available online
- UL1480 certified



AD-P.SUB



### Background Music Applications · Retail · Restaurants · Coffee Shops · Fine Dining · Hospitality · Commercial Spaces

The QSC AD-P.SUB is part of the AcousticDesign™ Series SUB/SAT loudspeaker line which are ideally suited for background music applications that require refined depth and clarity even at lower volume settings.

The AcousticDesign Series offers integrators a premium quality installed sound solution where performance, consistent coverage, and aesthetics are paramount. Specifically designed to maintain a consistent tonal characteristic across the entire family in ceiling, surface, and pendant enclosures, the AcousticDesign Series allows integrators seamless transitions within blended installations.

The AcousticDesign Series SUB/SAT loudspeakers have been specifically designed to be mix-and-match capable. Any combination of satellites may be paired with any subwoofer in the SUB/SAT line.

The AD-P.SUB features a high quality 6.5-inch weather treated paper cone woofer on a dual voice-coil for improved thermal dissipation and higher output within a small form factor.

The accurate frequency response of the AD-P.SUB is maintained even in 70 / 100 V applications by use of a low-loss, low-saturation 100 W transformer with selectable taps, including 4  $\Omega$  bypass, using a rotary selector located under the snap-fit magnetically attached powder coat steel grill.

The AD-P.SUB includes built-in high-pass filtered outputs for connecting up to four AcousticDesign Series satellite loudspeakers. This feature greatly reduces system setup, amplifier channel count, and allows for ease of wiring.

The inputs and outputs are located behind a removable conduit cover plate with sealed gland nuts for cable dressing. All in-thru and outputs are terminated to locking 4-pole Euroblock style connectors capable of 12AWG (2 mm) wire thickness.

To retain their stylish aesthetics, the rugged ABS baffle is further protected by using UV inhibitors that prevent discoloration. The magnetic grille features a stick-on logo that can be removed blemish-free for installations where branding is not permitted.

Installers will appreciate the two quick-link cable assemblies and slip-lock fasteners to speed the installation.

Intrinsic Correction™ voicings that optimize performance and speed the install process are easily deployed via the MP-M Series music and paging mixers as well as Q-SYS Platform, including CXD-Q Series amplifiers, as part of a complete QSC systems solution.

The AD-P.SUB is available in QSC standard black (RAL 9011) or white (RAL 9010) and may be painted to match any decor.

For your system integration needs, complete EASE, CF2, CAD, and BIM files will be available for download at QSC.com.

# AD-P.SUB Details

## Sound pressure, Level

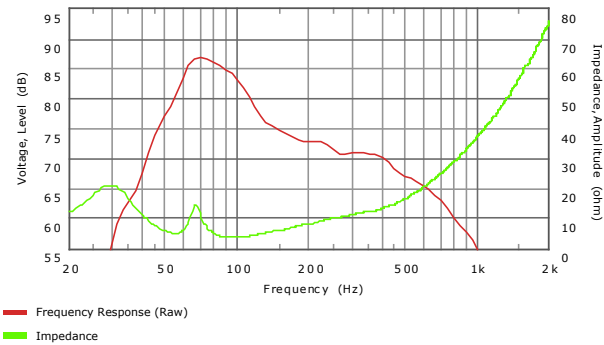

## Dimensions

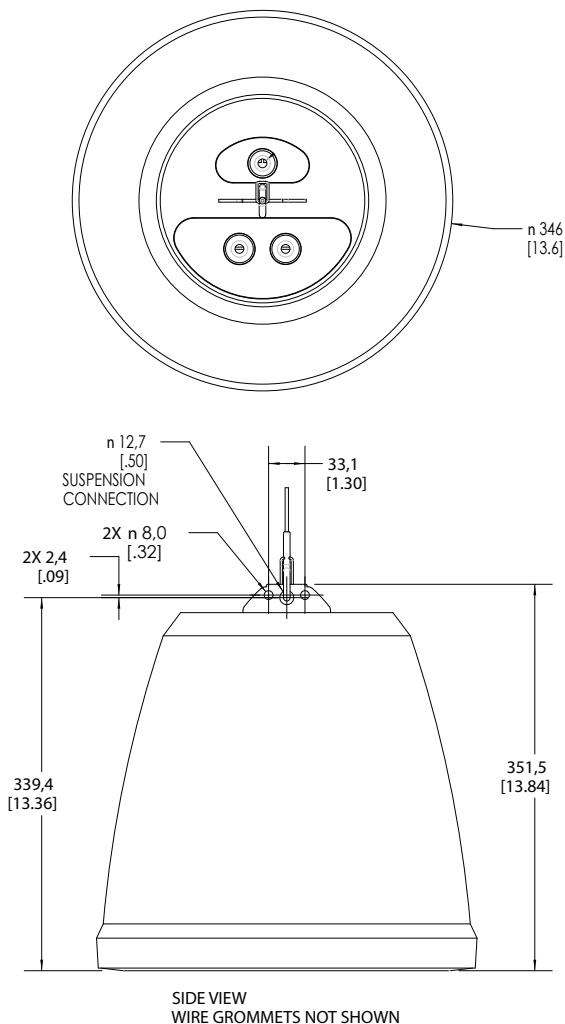

## Specifications

System Details	AD-P.SUB
LF transducer	6.5 in (165 mm) dual voice-coil weather treated paper cone woofer
HF transducer	N/A
Effective frequency range <sup>1,2</sup>	50 Hz – 150 Hz
Rated noise power / voltage <sup>4,6</sup>	100 W / 20 V (rms)
Sensitivity [dB] (rated @1 W, 1 m) <sup>3</sup>	86
Coverage (-6 dB)	Omni
Directivity index [dB] <sup>6</sup>	1.2
Directivity factor <sup>6</sup>	1.3
Maximum SPL [dB] (continuous / program / peak)	105 / 108 / 111
Recommended amplifier	100 W
Transformer taps / impedance	Bypass:4 Ω 100 W (70 V); NA (100 V) Tap: 50 Ω 50 W (70 V); 100 W (100 V) Tap: 100 Ω 25 W (70 V); 50 W (100 V) Tap: 200 Ω 12.5 W (70 V); 25 W (100 V) Tap: 400 Ω
Connectors	Mono input: 4-pole Euroblock with thru output Hi-pass mono output: 2x 4-pole Euroblock for 4x satellites
Enclosure material	ABS
Grille material	Powder coated steel
Ingress protection	IP-34
Operating environment	Designed for indoor use
Operating temperature range	-4 to 122° F (-20 to 50° C)
Net weight	17.53 lb (7.95 kg)
Product dimensions (Ø x H)	Ø 13.6 x 14.1 in (Ø 346 x 359 mm)
Shipping weight	21.8 lb / 9.89 kg
Shipping dimensions (H x W x D)	17.1 x 17.1 x 17.1 in (435 x 435 x 435 mm)
Included accessories	2x cable rigging, 3x Euroblock connector, 2x sealed input cover, grill
Safety agency	UL1480, Transformer UL registered per UL1876, ROHS, CE compliant.

As part of QSC's ongoing commitment to product development, specifications are subject to change without notice.

## Footnotes:

- 1) -10 dB from rated sensitivity, free space
- 2) Reference plane is the plane coincident with the loudspeaker baffle plane. Reference axis is the axis perpendicular to the reference plane and passing through the center of the baffle. Vertical plane is the plan intersecting the reference plane at a right angle, including the reference axis and the taps selector knob. Horizontal plane is the plane intersecting the reference plane and the vertical plane at a right angle, including the reference axis.
- 3) Calculated from Thiele-Small parameters.
- 4) IEC, 2hrs, 16 ohm nominal, rated noise power (W), rated noise voltage (Vrms).
- 5) Calculated from rated noise power and sensitivity
- 6) 50 Hz - 200 Hz

