



## RSC-112

### Screen Channel Loudspeaker Reference Monitor System

#### Features

- Studio reference-quality loudspeaker system
- Part of the QSC Reference Monitor System, including matched subwoofer, signal processing, and amplification
- Optimized for use behind a perforated screen
- DMT™ (Directivity Matched Transition) ensures smooth, coherent power response throughout the listening area
- 90° Axisymmetric horn
- 12" (305 mm) woofer with 4" (102 mm) voice coil
- 3.5" (90 mm) diaphragm MF compression driver with coaxial 1.75" (44 mm) HF compression driver
- M10 threaded inserts offer flexible and safe deployment options for a variety of applications
- Optional RBK-12 baffle wing kit
- NL8 Speakon™ connectors
- 15-ply Baltic birch plywood construction



The RSC-112 is the screen channel component of the QSC Reference Monitor System, a high performance, studio-quality loudspeaker system for critical mixing, monitoring, and presentation. Each RSC-112 3-way loudspeaker is paired with a matching RSB-212 dual-driver subwoofer and factory-specified signal processing and power amplification for optimal performance when sound quality is paramount.

The RSC-112 features a 12" (305 mm) woofer with 4" (102 mm) voice coil for exceptional low frequency bandwidth reproduction. The LF driver crosses over into a high power capacity, neodymium mid frequency compression driver with 3.5" (90 mm) voice coil and coaxially-mounted 1.75" (44 mm) voice coil high frequency driver.

The coaxial neodymium mid/ high-frequency compression driver unit provides a dramatic improvement in dynamic response, clarity and transparency. The annular mid-frequency diaphragm covers the frequency range between 1200 and 7000 Hz with a smooth, linear response. The large diaphragm excursion of +/-0.8 mm results in high output and increased power handling. The high-frequency driver covers the frequency range from 7000 Hz to 20 kHz and eliminates the dome break up of conventional drivers that can cause resonance and harsh, metallic sound.

The uniform power-response of the RSC-112 loudspeaker is a result of DMT™ (Directivity Matched Transition), a design approach that matches LF and HF coverage in the cross-

over region. Another key to the extraordinary accuracy and flat power response of the RSC-112 is the axisymmetric waveguide, which provides uncompromised performance in both the vertical and horizontal axes. The RSC-112 provides coverage over a 90° angle, ideal for small room monitoring or playback applications.

Each RSC-112 receives customized signal processing from a matched QSC Q-Sys™ processor core. The Q-Sys core provides Intrinsic Correction™, which is a set of proprietary DSP tunings implemented in FIR filters that provide the most accurate acoustical magnitude, frequency, and phase domain performance possible. Intrinsic Correction can compensate for many causal phenomena such as the effects of waveguide acoustical impedance and loudspeaker cone resonances, resulting in flat power response and extremely natural, uncolored sound.

Legendary QSC DCA power amplifiers deliver the precise level of amplification to get the most out of each RSC-112, producing the cleanest sound with nearly undetectable levels of distortion.

For installations where there is no baffle wall, the RSC-112 (along with the RSB-212 subwoofer) can be installed with optional baffle wings (RBK-12) which provide low frequency loading and minimize behind-screen reflections.

# RSC-112 Details

System Details	RSC-112
Rated Coverage Angle (-6 dB)	90 degrees Axisymmetric
Frequency Range <sup>1</sup> (-10dB)	55 Hz to 20 kHz
Crossover Frequencies	80 to 120 Hz (selectable), 1.2 kHz, 7 kHz up to 48 dB/oct using dedicated Q-Sys DSP
Rated Noise Power (Voltage) <sup>2</sup>	LF: 500 W / 63 V   MF: 80 W / 25 V   HF: 55 W / 20 V
Sensitivity <sup>3</sup>	LF: 94 dB   MF: 107 dB   HF: 105 dB
Maximum continuous SPL <sup>4</sup>	LF: 121   MF: 126   HF: 122
Maximum peak SPL <sup>4</sup>	LF: 127   MF: 132   HF: 128
Rated Impedance	LF: 8Ω, MF: 8Ω, HF: 8Ω
Recommended Amplifier Power	LF: 1000 W   MF: 500 W   HF: 300 W
Transducers	LF: 12 in. (305 mm) woofer MF/HF: coaxial neodymium compression driver with 3.5" (90mm) MF voice coil and 1.75" (44mm) HF voice coil
Enclosure Details	
Input Connector	Parallel NL8: 1/to sub, 2/LF, 3/MF, 4/HF
Enclosure Material	15-ply Baltic birch plywood
Dimensions (HxWxD)	28.5" x 15.1" x 13.5" (725 x 383 x 344 mm)
Net Weight	66.4 lb (30.1 kg)
Included Accessories	None
Optional Accessories	RBK-12 baffle wing kit

As part of QSC's ongoing commitment to product development, specifications are subject to change without notice.

<sup>1</sup> Free-field, unprocessed, -10 dB from on-axis sensitivity

<sup>2</sup> AES2-1984 noise signal for 2 hrs

<sup>3</sup> On-Axis, free-field sensitivity, 2.83V, 1 m

<sup>4</sup> Calculated from rated noise voltage and sensitivity

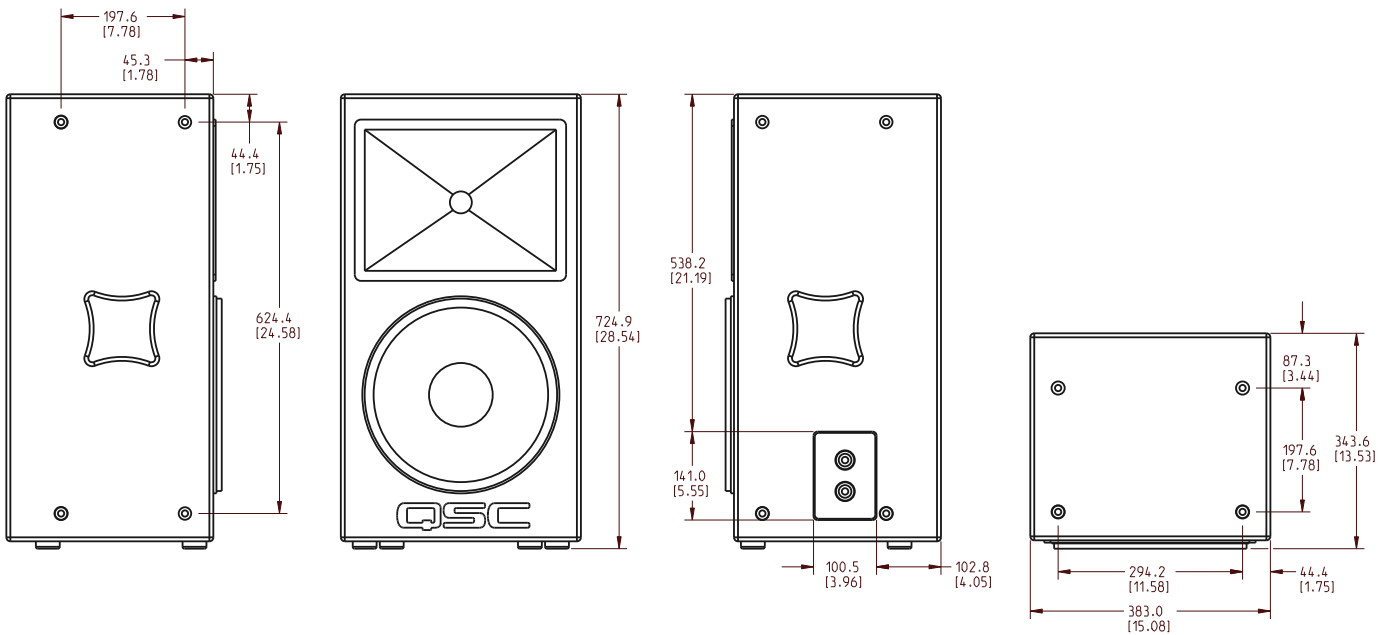

Specifications subject to change without notice.



1675 MacArthur Boulevard • Costa Mesa, CA 92626 • Ph: 800/854-4079 or 714/957-7100 • Fax: 714/754-6174



please recycle

© 2013 QSC and the QSC logo are registered trademarks of QSC Audio Products, LLC in the U.S. Patent and Trademark office and other countries. DMT, Intrinsic Correction, and Q-Sys are trademarks of QSC. Speakon is a registered trademark of Neutrik. All other trademarks are the property of their respective owners. Patents may apply or be pending.