

Blackmagic URSA Broadcast G2



\$4,195

The new Blackmagic URSA Broadcast G2 is an incredibly powerful camera designed for both traditional and online broadcasters. The 3 cameras in 1 design allows it to work as a 4K production camera, a 4K studio camera or a 6K digital film camera! You can record to common SD cards, UHS-II cards, CFast 2.0 cards or external USB disks, using common file formats such as H.265, ProRes and Blackmagic RAW. You can even change the lens mount! No other broadcast camera is so flexible!

Camera Features

Effective Sensor Size

2/3 inch sensor size when using 4K B4 mount
(Actual sensor size
23.10mm x 12.99mm)

Lens Mount

B4 2/3 inch installed
Active EF mount also included

Lens Control

Electronic control via 12-pin broadcast connector. Control via EF mount pins when using URSA Mini Pro EF Mount with compatible EF lenses.

Lens Correction

In-camera correction of color fringing when using compatible broadcast lenses.

Dynamic Range

13 Stops

Dual Native ISO

0dB and 18dB gain.

Sensitivity at 0dB Gain

f11 with 2160p59.94.
f12 with 2160p50.
at 2,000 lux with 89.9% reflectance.
additional 1.1 stop light loss using 4K B4 mount.

Signal to Noise Ratio

64.62dB for 2160p
Ultra HD scaled from 5.3K

Built in ND Filters

Four position ND filter wheel with clear, 2 stop, 4 stop and 6 stop ND filters.

Focus

Focus button triggers auto focus when using compatible lenses with focus servo. Touch and hold on LCD determines focus region and triggers auto focus.

Iris Control

Iris wheel and touchscreen slider for manual iris adjustment on electronically controllable lenses, iris button for instant auto iris settings on compatible lenses so no pixel is clipped in film mode. Scene average auto exposure in video and extended video mode.

Screen Dimensions

4 inch

Screen Type

LCD capacitive touchscreen.

Controls

Touchscreen menus on 4 inch screen. Push buttons for other controls. 3 assignable shortcut keys and 2 assignable shortcut keys (VTR and RET) on compatible broadcast lenses.

ProRes Shooting Resolutions and**Frame Rates**

3840 x 2160 (Ultra HD) up to 60 fps
from Ultra HD window or scaled from
5.3K windowed sensor

3840 x 2160 (Ultra HD) up to 50 fps
scaled from full sensor

1920 x 1080 (HD) up to 120 fps

scaled from 2.7K windowed sensor

1920 x 1080 (HD) up to 60 fps

scaled from Ultra HD or 5.3K
windowed sensor

1920 x 1080 (HD) up to 50 fps

scaled from full sensor

H.265 Shooting Resolutions and**Frame Rates**

3840 x 2160 (Ultra HD) up to 60 fps
from Ultra HD window or scaled from
5.3K windowed sensor

3840 x 2160 (Ultra HD) up to 50 fps
scaled from full sensor

H.264 Shooting Resolutions and**Frame Rates**

1920 x 1080 (HD) up to 60 fps
scaled from Ultra HD or 5.3K
windowed sensor

1920 x 1080 (HD) up to 50 fps

scaled from full sensor

Blackmagic RAW Shooting**Resolutions and Frame Rates**

6144 x 3456 (6K) up to 50 fps

6144 x 2560 (6K 2.4:1) up to 60 fps

5376 x 3024 (5.3K 16:9) up to 60 fps

3728 x 3104 (3.7K 6:5 anamorphic)
up to 60 fps

3840 x 2160 (Ultra HD) up to 60 fps

1920 x 1080 (HD) up to 150 fps

Project Frame Rates

23.98, 24, 25, 29.97, 30, 50, 59.94 and
60 fps.

Off-speed frame rates up to 60p in
Ultra HD and up to 150p in HD.

Metadata Support

Automatically populated lens data
from electronic B4 lenses. Automatic
recording of camera settings and
slate data such as project, scene
number, take and special notes.

Timecode Clock

Highly accurate timecode clock. Less
than 1 frame drift every 8 hours.

Connections**SDI Video Inputs**

1

SDI Video Outputs

1

SDI Monitor Outputs

1

SDI Rates

1.5G, 3G, 6G, 12G.

Analog Audio Inputs

2 x XLR switchable between mic, line
and AES digital audio. Phantom
power support.

Analog Audio Outputs

1 x 3.5mm headphone jack, supports
iPhone style headset for talkback.

Reference Inputs

Tri-Sync/Black Burst/Timecode.

Lens Control

1 x 12-pin Hirose Broadcast Lens
Connector

Remote Control

1 x 2.5mm LANC input for Rec Start/
Stop, plus Iris and Focus control using
compatible lenses.

Computer Interface

1 x USB Type-C 3.1 Gen 2 with power
delivery for external drive recording
and connecting Blackmagic Focus and
Zoom Demand. 1 x USB Type-C for
software updates.

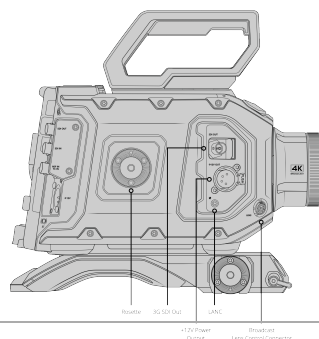
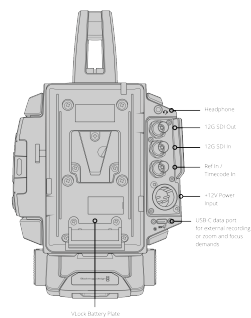
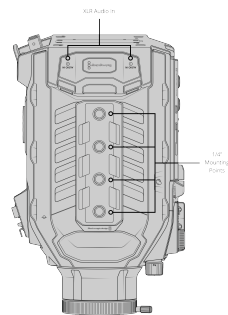
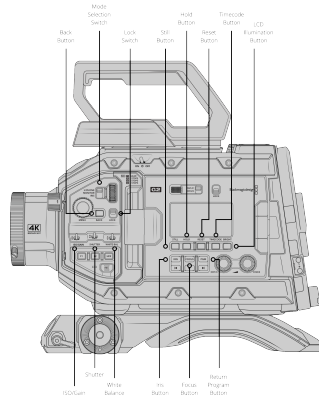
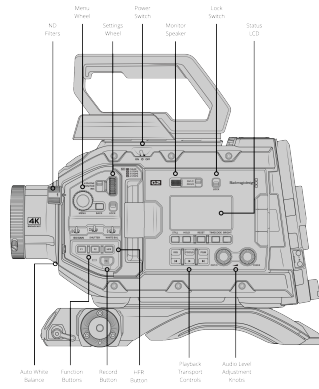

Audio

Microphone

Integrated stereo microphone.

Built in Speaker

1 x mono speaker.

Standards

SD Video Standards

None

HD Video Standards

1080p23.98, 1080p24, 1080p25,
1080p29.97, 1080p30, 1080p50,
1080p59.94, 1080p60 1080i50,
1080i59.94, 1080i60

Ultra HD Video Standards

2160p23.98, 2160p24, 2160p25,
2160p29.97, 2160p30, 2160p50,
2160p59.94, 2160p60

SDI Compliance

SMPTE 292M, SMPTE 424M,
SMPTE 425M level A and B,
SMPTE 2081-1, SMPTE 2081-10,
SMPTE 2082-1 and SMPTE 2082-10

SDI Audio Sampling

48 kHz and 24 bit

Media

Media

2 x CFast 2.0 card slots, 2 x SD
UHS-II card slots, 1 x USB-C 3.1 Gen 2
expansion port with power delivery
for recording to external media.

Media Format

Can format media to ExFAT for
Windows and Mac or HFS+ for Mac
(file systems).

Please refer to either the Manual or the Information Note at www.blackmagicdesign.com/support for compatible media.

Supported Codecs

Codecs

Apple ProRes 422 HQ,
Apple ProRes 422,
H.265 SDI (10-bit 4:2:2),
H.265 High (10-bit 4:2:0),
H.265 Medium (10-bit 4:2:0),
H.265 Low (10-bit 4:2:0),
H.264 SDI (10-bit 4:2:2),
H.264 High (8-bit 4:2:0),
H.264 Medium (8-bit 4:2:0),
H.264 Low (8-bit 4:2:0),
Blackmagic RAW Constant Bitrate 3:1,
Blackmagic RAW Constant Bitrate 5:1,
Blackmagic RAW Constant Bitrate 8:1,
Blackmagic RAW Constant Bitrate 12:1,
Blackmagic RAW Constant Quality Q0,
Blackmagic RAW Constant Quality Q1,
Blackmagic RAW Constant Quality Q3,
Blackmagic RAW Constant Quality Q5

Control

External Control

Lens control of compatible lenses using Blackmagic Zoom Demand and Blackmagic Focus Demand, Blackmagic SDI Control Protocol, iPad control via Bluetooth, 1 x 2.5mm LANC for lens and record control.

Color Corrector

Color Corrector

DaVinci YRGB.

Talkback and Tally

Talkback

SDI Channels 15/16 and iPhone headset.

Live Tally Indicator

Tally on LCD, URSA Viewfinder and URSA Studio Viewfinder.

Storage Features

Storage Type

2 x CFast 2.0
2 x SD UHS-II cards
1 x high speed USB-C expansion port for external media.
2.5 inch SSD using optional URSA Mini Recorder

Storage Rates

Storage rates based on 30 frames per second.

| | |
|-------------------------------------|------------------------------------|
| 6144 x 3456 (6K) | 3840 x 2160 (Ultra HD) |
| Blackmagic RAW 3:1 - 323 MB/s | Apple ProRes 422 HQ - 110 MB/s |
| Blackmagic RAW 5:1 - 194 MB/s | Apple ProRes 422 - 73.6 MB/s |
| Blackmagic RAW 8:1 - 121 MB/s | H.265 SDI - 12.3 MB/s |
| Blackmagic RAW 12:1 - 81 MB/s | H.265 High - 10.8 MB/s |
| Blackmagic RAW Q0 - 242 to 483 MB/s | H.265 Medium - 7.8 MB/s |
| Blackmagic RAW Q1 - 162 to 387 MB/s | H.265 Low - 3.2 MB/s |
| Blackmagic RAW Q3 - 108 to 277 MB/s | Blackmagic RAW 3:1 - 127 MB/s |
| Blackmagic RAW Q5 - 65 to 162 MB/s | Blackmagic RAW 5:1 - 77 MB/s |
| 6144 x 2560 (6K 2.4:1) | Blackmagic RAW 8:1 - 48 MB/s |
| Blackmagic RAW 3:1 - 240 MB/s | Blackmagic RAW 12:1 - 32 MB/s |
| Blackmagic RAW 5:1 - 144 MB/s | Blackmagic RAW Q0 - 96 to 190 MB/s |
| Blackmagic RAW 8:1 - 90 MB/s | Blackmagic RAW Q1 - 64 to 153 MB/s |
| Blackmagic RAW 12:1 - 60 MB/s | Blackmagic RAW Q3 - 43 to 109 MB/s |
| Blackmagic RAW Q0 - 180 to 359 MB/s | Blackmagic RAW Q5 - 26 to 64 MB/s |
| Blackmagic RAW Q1 - 120 to 287 MB/s | 1920 x 1080 |
| Blackmagic RAW Q3 - 80 to 205 MB/s | Apple ProRes 422 HQ - 27.5 MB/s |
| Blackmagic RAW Q5 - 49 to 120 MB/s | Apple ProRes 422 - 18.4 MB/s |
| 5376 x 3024 (5.3K 16:9) | H.264 SDI - 7.0 MB/s |
| Blackmagic RAW 3:1 - 248 MB/s | H.264 High - 5.6 MB/s |
| Blackmagic RAW 5:1 - 149 MB/s | H.264 Medium - 3.2 MB/s |
| Blackmagic RAW 8:1 - 94 MB/s | H.264 Low - 1.8 MB/s |
| Blackmagic RAW 12:1 - 63 MB/s | Blackmagic RAW 3:1 - 19 MB/s |
| Blackmagic RAW Q0 - 186 to 371 MB/s | Blackmagic RAW 5:1 - 12 MB/s |
| Blackmagic RAW Q1 - 125 to 297 MB/s | Blackmagic RAW 8:1 - 7.8 MB/s |
| Blackmagic RAW Q3 - 84 to 213 MB/s | Blackmagic RAW 12:1 - 5.2 MB/s |
| Blackmagic RAW Q5 - 51 to 125 MB/s | Blackmagic RAW Q0 - 23 to 47 MB/s |
| 3728 x 3104 (3.7K 6:5 anamorphic) | Blackmagic RAW Q1 - 16 to 37 MB/s |
| Blackmagic RAW 3:1 - 177 MB/s | Blackmagic RAW Q3 - 10 to 27 MB/s |
| Blackmagic RAW 5:1 - 106 MB/s | Blackmagic RAW Q5 - 6 to 16 MB/s |
| Blackmagic RAW 8:1 - 67 MB/s | |
| Blackmagic RAW 12:1 - 45 MB/s | |
| Blackmagic RAW Q0 - 133 to 265 MB/s | |
| Blackmagic RAW Q1 - 89 to 212 MB/s | |
| Blackmagic RAW Q3 - 60 to 152 MB/s | |
| Blackmagic RAW Q5 - 36 to 89 MB/s | |

Constant Quality storage rates quoted are indicative only.

Actual storage rates are entirely dependent on image subject matter.

Recording Formats

Apple ProRes 3840 x 2160 and 1920 x 1080 with film, video or extended video dynamic range or custom 3D LUT.

H.265 3840 x 2160 with film, video or extended video dynamic range or custom 3D LUT.

H.264 1920 x 1080 with film, video or extended video dynamic range or custom 3D LUT.

Blackmagic RAW Q0, Q1, Q3, Q5, 3:1, 5:1, 8:1 and 12:1 at 6144 x 3456, 6144 x 2560, 5376 x 3024, 3728 x 3104, 3840 x 2160, 1920 x 1080 recorded in non-linear 12 bit with film dynamic range and extended video, video or custom 3D LUT embedded in metadata.

Software

Software Included

Blackmagic OS

DaVinci Resolve Studio for Mac and Windows including activation key

Blackmagic Camera Setup

Blackmagic RAW Player

Blackmagic RAW QuickLook Plugin

Blackmagic RAW SDK

Blackmagic RAW Speed Test

Operating Systems



Mac 10.15 Catalina,
Mac 11.1 Big Sur or later.



Windows 10, 64-bit.

Power Requirements

Power Supply

1 x External 12V DC 100W power supply with 100 - 240V AC 50/60Hz IEC C14 input.

External Power Input

1 x 4-pin XLR port for external mains power supply or battery use.

1 x 12-pin Molex connector under rear battery plate.

Power Output

+12V 4-pin XLR regulated output on side of camera

+12V D-Tap regulated output on VLock battery plate

Power

Rear camera mount compatible with industry standard V-mount or gold mount battery plates.

Accessories

Optional Accessories

Blackmagic URSA Viewfinder
Blackmagic URSA Studio Viewfinder
Blackmagic Camera Fiber Converter
Blackmagic Studio Fiber Converter
Blackmagic URSA Mini Pro PL Mount
Blackmagic URSA Mini Pro F Mount
Blackmagic URSA Mini Mic Mount
Blackmagic URSA Mini Recorder
Blackmagic URSA Gold Battery Plate

Physical Specifications



Environmental Specifications

Operating Temperature

0° to 40°C (32° to 104°F)

Storage Temperature

-20° to 45°C (-4° to 113°F)

Relative Humidity

0% to 90% non-condensing

What's Included

Blackmagic URSA Broadcast G2
4K B4 lens mount installed
B4 turret dust cap
EF Mount with dust cap
VLock Battery Plate installed
URSA 12V 100W power supply
URSA Mini Shoulder Pad
URSA Mini top handle & rubber stopper
Viewfinder mounting plate
2 x 1/4 inch baseplate screws
2 x long 1/4 inch top handle screws
2 x short 1/4 inch top handle screws
8 x EF Mount screws
4 x VLock plate spare screws
Welcome wallet with QR code for camera software download
DaVinci Resolve Studio wallet
DaVinci Resolve Studio activation key

Warranty

12 Month Limited
Manufacturer's Warranty.

All items on this website are copyright Blackmagic Design Pty. Ltd. 2023, all rights reserved. All trademarks are property of their respective owners. MSRP includes duties, but excludes sales tax and shipping costs. This website uses remarketing services to advertise on third party websites to previous visitors to our site. You can opt out at any time by changing cookie settings. [Privacy Policy](#)

Blackmagic Design Authorized Reseller