

# XCM 50

COMPACT USB CONDENSER MICROPHONE  
FOR STREAMERS AND GAMERS

The XCM-50 is a professional condenser USB microphone optimised for streaming and gaming. It delivers highly detailed audio, with a full frequency response and tight cardioid polar pattern tuned for speech applications. It has a zero-latency headphone output with level control and mute functionality, a 360-degree swing mount for easy positioning, and comes with a tripod desktop mount. The XCM-50 also comes with a free download of UNIFY virtual mixing software, which unlocks advanced audio processing, powered by internal DSP. Together, they offer a complete audio solution for streaming and gaming.

- Professional condenser USB Microphone
- Complete audio solution for streaming and gaming with included UNIFY software
- Highly detailed audio capture optimised for voice applications
- Tight cardioid polar pattern
- Zero-latency headphone output with level control and mute button
- Internal DSP for advanced audio processing
- Plug-and-play USB-C connectivity with 24-bit, 48kHz analog-digital conversion
- Integrated 360-degree swing mount
- Desktop tripod included



STUDIO QUALITY



INTERNAL  
POP FILTER



HEADPHONE  
OUTPUT JACK



USB AUDIO  
COMPATIBLE

## ACOUSTIC & ELECTRICAL SPECIFICATIONS

Polar Pattern:	Cardioid
Capsule:	Condenser
Frequency Range:	20 Hz – 20 kHz
Connectivity:	USB-C
Analog Outputs:	3.5mm Headphone Output
Sample Rate:	48 kHz
Bit Depth:	24-bit
OS Requirements:	macOS 10.12 Windows 10

## MECHANICAL SPECIFICATIONS

Weight (grams):	492g
Dimensions (millimetres):	Width: 62 Depth: 42 Height: 118
Included Accessories:	Tripod 2 SC29 USB-C to USB-C cable 3m Headphone Extension Cable

## WHATS IN THE BOX



XCM-50



Tripod 2



SC29



SC30

## DIMENSIONS

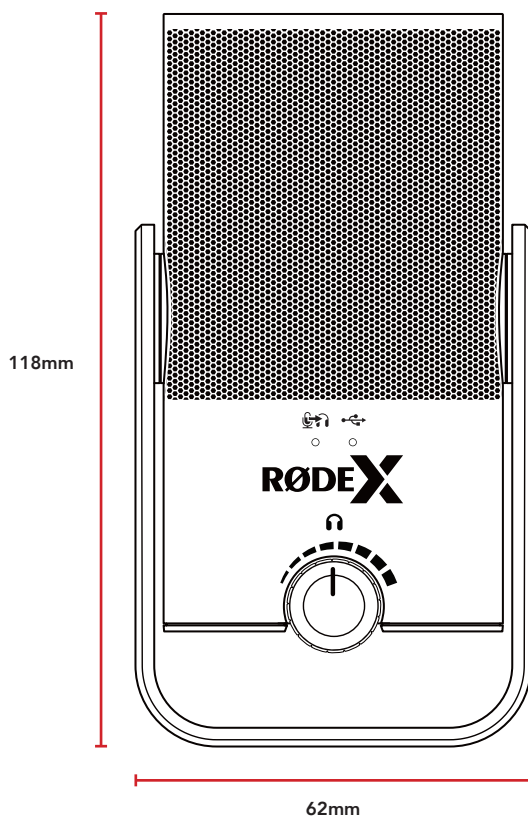

## POLAR PATTERN

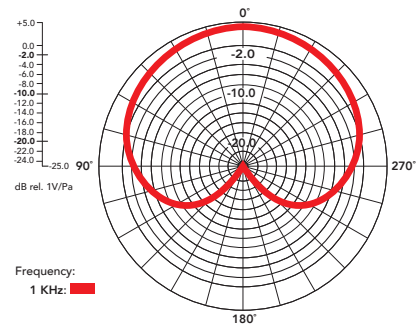

## FREQUENCY RESPONSE

